

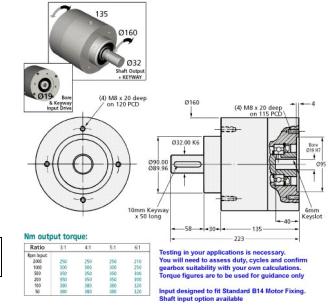

# MBA

## Gearboxes - Inline - Epicyclic - 160.0 x 135.0mm



Servo Gearbox 180Nm to 380Nm ratios 3:1 - 6:1. EHD16 Series.

- Case: Steel.
- Gears: Steel EN36 655M13 EN24T 817M40T.
- Weight: 18.86kg Backlash: 30'.
- Max Input Speed: 2,000 Rpm (short term).
- Lubrication: Greased for life - Shell Nerita Grease HV.

### Gearboxes - Inline - Epicyclic - 160.0 x 135.0mm

Part Number	Ratio	Max. Input Speed	Max. Output Speed	Efficiency at 1000 Rpm Percent	Nm output at 1000 Rpm Nm	Direction
# EHD16-3	3 : 1	2000	666.66	92	300	Same
# EHD16-4	4 : 1	2000	500	92	300	Same
# EHD16-5	5 : 1	2000	400	92	300	Same
# EHD16-6	6 : 1	2000	333.33	92	250	Same



DISTRIBUTED BY

Ask us to put your name and address here

<http://www.minibearings.com.au/product>

Ph +61 7 3245 7977

Fax +61 7 3245 1017

Catalogue requests to [catalogues@minibearings.com.au](mailto:catalogues@minibearings.com.au)
