

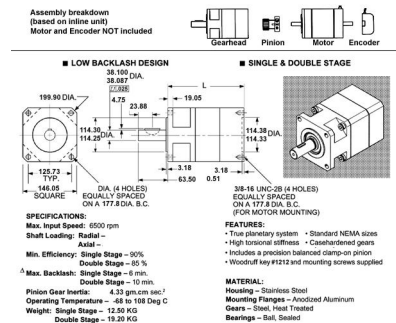

MBA

Gearheads - Inline - Planetary - Size 56 - Precision



Use with NEMA Size 56 Motors.

Stainless Steel housing - Heat Treated Steel Gears - Sealed ball bearings - Aluminium mounting flange.

Shaft loading 937kg (2100 lbs) radial and 937kg (2100 lbs) axial / Maximum input speed 6500 rpm.

Min. Efficiency ---- Single Stage : 90%, Double Stage : 85%.

Max Backlash ---- Single Stage : 6 arc min, Double Stage : 10 arc min.

Operating Temperature : -54 to 121 Deg C (-65 to 250 Deg F).

This catalogue to be read in conjunction with information at http://www.minibearings.com.au/ogue/tech/gearheads/Nema_Sizes.pdf

http://www.minibearings.com.au/ogue/tech/gearheads/Gear_Types.pdf

Gearheads - Inline - Planetary - Size 56 - Precision

Part Number	Ratio	Motor Shaft Diameter mm	Config. / Output Shaft	Bolt Circle mm	Motor Shaft Length mm	Max Rated Cont. Torque N.m	Unit Width / Pilot Dia. (A/E) mm	Length (L) mm
		<i>inches</i>		<i>inches</i>	<i>inches</i>		<i>inches</i>	<i>inches</i>
# GHIP56-003-28.58x178P	3 : 1	28.58	Single Stage / 38.10	177.80	Max 60.32	Under Review	146.05 / 114.37	161.3
		<i>1.125</i>		<i>7.000</i>				<i>6.350</i>
# GHIP56-004-28.58x178P	4 : 1	28.58	Single Stage / 38.10	177.80	Max 60.32	Under Review	146.05 / 114.37	161.3
		<i>1.125</i>		<i>7.000</i>				<i>6.350</i>

Indicates item not stocked at time of printing - Please enquire for lead time

E&OE Pricing and all details subject to change without notice - Copyright Miniature Bearings Australia Pty Ltd

MBA Size Listings are a guide to sizes only and must not be solely relied on for critical design information.

Gearheads - Inline - Planetary - Size 56 - Precision

Part Number	Ratio	Motor Shaft Diameter mm	Config. / Output Shaft	Bolt Circle mm	Motor Shaft Length mm	Max Rated Cont. Torque N.m	Unit Width / Pilot Dia. (A/E) mm	Length (L) mm
		<i>inches</i>		<i>inches</i>	<i>inches</i>		<i>inches</i>	<i>inches</i>
# GHIP56-006-28.58x178P	5.5 : 1	28.58	Single Stage / 38.10	177.80	Max 60.32	Under Review	146.05 / 114.37	161.3
		<i>1.125</i>		<i>7.000</i>				<i>6.350</i>
# GHIP56-007-28.58x178P	7 : 1	28.58	Single Stage / 38.10	177.80	Max 60.32	Under Review	146.05 / 114.37	161.3
		<i>1.125</i>		<i>7.000</i>				<i>6.350</i>
# GHIP56-010-28.58x178P	10 : 1	28.58	Single Stage / 38.10	177.80	Max 60.32	Under Review	146.05 / 114.37	161.3
		<i>1.125</i>		<i>7.000</i>				<i>6.350</i>
# GHIP56-016-28.58x178P	16 : 1	28.58	Double Stage / 38.10	177.80	Max 60.32	Under Review	146.05 / 114.37	215.9
		<i>1.125</i>		<i>7.000</i>				<i>8.500</i>
# GHIP56-022-28.58x178P	22 : 1	28.58	Double Stage / 38.10	177.80	Max 60.32	Under Review	146.05 / 114.37	215.9
		<i>1.125</i>		<i>7.000</i>				<i>8.500</i>
# GHIP56-028-28.58x178P	28 : 1	28.58	Double Stage / 38.10	177.80	Max 60.32	Under Review	146.05 / 114.37	215.9
		<i>1.125</i>		<i>7.000</i>				<i>8.500</i>
# GHIP56-040-28.58x178P	40 : 1	28.58	Double Stage / 38.10	177.80	Max 60.32	Under Review	146.05 / 114.37	215.9
		<i>1.125</i>		<i>7.000</i>				<i>8.500</i>
# GHIP56-049-28.58x178P	49 : 1	28.58	Double Stage / 38.10	177.80	Max 60.32	Under Review	146.05 / 114.37	215.9
		<i>1.125</i>		<i>7.000</i>				<i>8.500</i>

Indicates item not stocked at time of printing - Please enquire for lead time

E&OE Pricing and all details subject to change without notice - Copyright Miniature Bearings Australia Pty Ltd

MBA Size Listings are a guide to sizes only and must not be solely relied on for critical design information.

Gearheads - Inline - Planetary - Size 56 - Precision

Part Number	Ratio	Motor Shaft Diameter mm	Config. / Output Shaft	Bolt Circle mm	Motor Shaft Length mm	Max Rated Cont. Torque N.m	Unit Width / Pilot Dia. (A/E) mm	Length (L) mm
		<i>inches</i>		<i>inches</i>	<i>inches</i>		<i>inches</i>	<i>inches</i>
# GHIP56-055-28.58x178P	55 : 1	28.58	Double Stage / 38.10	177.80	Max 60.32	Under Review	146.05 / 114.37	215.9
		<i>1.125</i>		<i>7.000</i>				<i>8.500</i>
# GHIP56-070-28.58x178P	70 : 1	28.58	Double Stage / 38.10	177.80	Max 60.32	Under Review	146.05 / 114.37	215.9
		<i>1.125</i>		<i>7.000</i>				<i>8.500</i>
# GHIP56-100-28.58x178P	100 : 1	28.58	Double Stage / 38.10	177.80	Max 60.32	Under Review	146.05 / 114.37	215.9
		<i>1.125</i>		<i>7.000</i>				<i>8.500</i>

Indicates item not stocked at time of printing - Please enquire for lead time

E&OE Pricing and all details subject to change without notice - Copyright Miniature Bearings Australia Pty Ltd

MBA Size Listings are a guide to sizes only and must not be solely relied on for critical design information.



DISTRIBUTED BY

Ask us to put your name and address here

<http://www.minibearings.com.au/product>

Ph +61 7 3245 7977

Fax +61 7 3245 1017

Catalogue requests to catalogues@minibearings.com.au

