

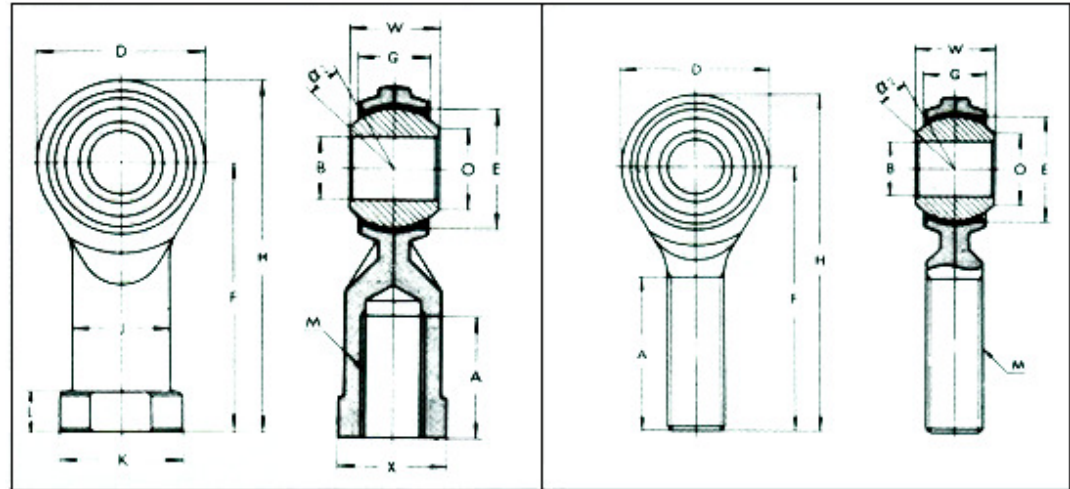

# MBA

## Rod Ends - Steel - Bronze Lined

Imperial and Metric / Carbon steel and Stainless Steel.  
 Dimensions not shown are available on request.  
 CFF.SS series are made to DIN 648K and ISO 6126JK.



**FEMALE**

**MALE**

## Rod Ends - Steel - Bronze Lined

Part Number	Eye Size (B) mm <i>inches</i>	Thread Size / Type mm <i>inches</i>	Widths (G/W/X/K) mm <i>inches</i>	Housing Dia. (D) mm <i>inches</i>	Height (H) mm <i>inches</i>	Centre Height (F) mm <i>inches</i>	Ball / Body / Seat	Thread Depth (A) mm <i>inches</i>	Grease Nipple	Static / Radial Load N
REM-03.00-R-B	3.00 <i>0.118</i>	M3 x 0.50 Male Right Hand	4.50 / 6.00 / - /-	12.00 <i>0.472</i>	33.00 <i>1.299</i>	27.00 <i>1.063</i>	High Carbon Chrome Steel / Chrome Steel / Bronze	15.00 <i>0.591</i>	No	
REF-03.00-L-B	3.00 <i>0.118</i>	M3 x 0.50 Female Left Hand	4.50 / 6.00 / 5.50 / 6.50	12.00 <i>0.472</i>	27.00 <i>1.063</i>	21.00 <i>0.827</i>	High Carbon Chrome Steel / Chrome Steel / Bronze	10.00 <i>0.394</i>	No	

## Rod Ends - Steel - Bronze Lined

Part Number	Eye Size (B) mm <i>inches</i>	Thread Size / Type mm <i>inches</i>	Widths (G/W/X/K) mm <i>inches</i>	Housing Dia. (D) mm <i>inches</i>	Height (H) mm <i>inches</i>	Centre Height (F) mm <i>inches</i>	Ball / Body / Seat	Thread Depth (A) mm <i>inches</i>	Grease Nipple	Static / Radial Load N
# REM-03.00-L-B	3.00 <i>0.118</i>	M3 x 0.50 Male Left Hand <i>inches</i>	4.50 / 6.00 / - / - <i>inches</i>	12.00 <i>0.472</i>	33.00 <i>1.299</i>	27.00 <i>1.063</i>	High Carbon Chrome Steel / Chrome Steel / Bronze	15.00 <i>0.591</i>	No	
REF-03.00-R-B	3.00 <i>0.118</i>	M3 x 0.50 Female Right Hand <i>inches</i>	4.50 / 6.00 / 5.50 / 6.50 <i>inches</i>	12.00 <i>0.472</i>	27.00 <i>1.063</i>	21.00 <i>0.827</i>	High Carbon Chrome Steel / Chrome Steel / Bronze	10.00 <i>0.394</i>	No	
# REF-04.00-L-B	4.00 <i>0.157</i>	M4 x 0.70 Female Left Hand <i>inches</i>	5.30 / 7.00 / 8.00 / 9.50 <i>inches</i>	14.00 <i>0.551</i>	31.00 <i>1.220</i>	24.00 <i>0.945</i>	High Carbon Chrome Steel / Chrome Steel / Bronze	12.00 <i>0.472</i>	No	
REF-04.00-R-B	4.00 <i>0.157</i>	M4 x 0.70 Female Right Hand <i>inches</i>	5.30 / 7.00 / 8.00 / 9.50 <i>inches</i>	14.00 <i>0.551</i>	31.00 <i>1.220</i>	24.00 <i>0.945</i>	High Carbon Chrome Steel / Chrome Steel / Bronze	12.00 <i>0.472</i>	No	
REM-04.00-R-B	4.00 <i>0.157</i>	M4 x 0.70 Male Right Hand <i>inches</i>	5.30 / 7.00 / - / - <i>inches</i>	14.00 <i>0.551</i>	37.00 <i>1.457</i>	30.00 <i>1.181</i>	High Carbon Chrome Steel / Chrome Steel / Bronze	17.00 <i>0.669</i>	No	
# REM-04.00-L-B	4.00 <i>0.157</i>	M4 x 0.70 Male Left Hand <i>inches</i>	5.30 / 7.00 / - / - <i>inches</i>	14.00 <i>0.551</i>	37.00 <i>1.457</i>	30.00 <i>1.181</i>	High Carbon Chrome Steel / Chrome Steel / Bronze	17.00 <i>0.669</i>	No	

# Indicates item not stocked at time of printing - Please enquire for lead time

E&OE Pricing and all details subject to change without notice - Copyright Miniature Bearings Australia Pty Ltd

MBA Size Listings are a guide to sizes only and must not be solely relied on for critical design information.

## Rod Ends - Steel - Bronze Lined

Part Number	Eye Size (B) mm <i>inches</i>	Thread Size / Type mm <i>inches</i>	Widths (G/W/X/K) mm <i>inches</i>	Housing Dia. (D) mm <i>inches</i>	Height (H) mm <i>inches</i>	Centre Height (F) mm <i>inches</i>	Ball / Body / Seat	Thread Depth (A) mm <i>inches</i>	Grease Nipple	Static / Radial Load N
# REM-04.83-R-B	4.83 <i>0.190</i>	10-32 UNF Male Right Hand <i>inches</i>	6.35 / 7.92 / - / - <i>inches</i>	15.88 <i>0.625</i>	39.70 <i>1.563</i>	31.75 <i>1.250</i>	High Carbon Chrome Steel / Chrome Steel / Bronze	19.05 <i>0.750</i>	No	
# REM-04.83-L-B	4.83 <i>0.190</i>	10-32 UNF Male Left Hand <i>inches</i>	6.35 / 7.92 / - / - <i>inches</i>	15.88 <i>0.625</i>	39.70 <i>1.563</i>	31.75 <i>1.250</i>	High Carbon Chrome Steel / Chrome Steel / Bronze	19.05 <i>0.750</i>	No	
# REF-04.83-R-B	4.83 <i>0.190</i>	10-32 UNF Female Right Hand <i>inches</i>	6.35 / 7.92 / 7.92 / 10.31 <i>inches</i>	15.88 <i>0.625</i>	34.93 <i>1.375</i>	26.97 <i>1.062</i>	High Carbon Chrome Steel / Chrome Steel / Bronze	14.27 <i>0.562</i>	No	
# REF-04.83-L-B	4.83 <i>0.190</i>	10-32 UNF Female Left Hand <i>inches</i>	6.35 / 7.92 / 7.92 / 10.31 <i>inches</i>	15.88 <i>0.625</i>	34.93 <i>1.375</i>	26.97 <i>1.062</i>	High Carbon Chrome Steel / Chrome Steel / Bronze	14.27 <i>0.562</i>	No	
# CFF.00.04S	5.00 <i>0.197</i>	M4 Female Right Hand <i>inches</i>	6.00 / 8.00 / 9.00 / 11.00 <i>inches</i>	18.00 <i>0.709</i>	36.00 <i>1.417</i>	27.00 <i>1.063</i>	High Carbon Chrome Steel / Chrome Steel / Bronze	10.00 <i>0.394</i>	No	
# REM-05.00-R-GAKFR5PB	5.00 <i>0.197</i>	M5 x 0.80 Male Right Hand <i>inches</i>	6.00 / 8.00 / - / - <i>inches</i>	18.10 <i>0.713</i>	42.40 <i>1.669</i>	33.00 <i>1.299</i>	High Carbon Chrome Steel / Chrome Steel / Bronze	20.00 <i>0.787</i>	Yes	

# Indicates item not stocked at time of printing - Please enquire for lead time

E&OE Pricing and all details subject to change without notice - Copyright Miniature Bearings Australia Pty Ltd

MBA Size Listings are a guide to sizes only and must not be solely relied on for critical design information.

## Rod Ends - Steel - Bronze Lined

Part Number	Eye Size (B) mm  <i>inches</i>	Thread Size / Type mm  <i>inches</i>	Widths (G/W/X/K) mm  <i>inches</i>	Housing Dia. (D) mm  <i>inches</i>	Height (H) mm  <i>inches</i>	Centre Height (F) mm  <i>inches</i>	Ball / Body / Seat	Thread Depth (A) mm  <i>inches</i>	Grease Nipple	Static / Radial Load N
REM-05.00-L-B	5.00	M5 x 0.80 Male Left Hand	7.00 / 8.00 / - / -	16.00	41.00	33.00	High Carbon Chrome Steel / Chrome Steel / Bronze	20.00	No	
	<i>0.197</i>			<i>0.630</i>	<i>1.614</i>	<i>1.299</i>		<i>0.787</i>		
# REF-05.00-L-B	5.00	M5 x 0.80 Female Left Hand	7.00 / 8.00 / 9.00 / 12.00	16.00	35.00	27.00	High Carbon Chrome Steel / Chrome Steel / Bronze	14.00	No	
	<i>0.197</i>			<i>0.630</i>	<i>1.378</i>	<i>1.063</i>		<i>0.551</i>		
REF-05.00-R-B	5.00	M5 x 0.80 Female Right Hand	7.00 / 8.00 / 9.00 / 12.00	16.00	35.00	27.00	High Carbon Chrome Steel / Chrome Steel / Bronze	14.00	No	
	<i>0.197</i>			<i>0.630</i>	<i>1.378</i>	<i>1.063</i>		<i>0.551</i>		
REM-05.00-R-B	5.00	M5 x 0.80 Male Right Hand	7.00 / 8.00 / - / -	16.00	41.00	33.00	High Carbon Chrome Steel / Chrome Steel / Bronze	20.00	No	
	<i>0.197</i>			<i>0.630</i>	<i>1.614</i>	<i>1.299</i>		<i>0.787</i>		
# REM-06.00-R-SA6C	6.00	M6 x 1.00 Male Right Hand	4.50 Max / 6.00 / - / -	21.00 Max	48.00 Max	42.00 Max	High Carbon Chrome Steel / Chrome Steel / PTFE Lined	21.00	Yes	
	<i>0.236</i>							<i>0.827</i>		
# REM-06.00-L-SAL6C	6.00	M6 x 1.00 Male Left Hand	4.50 Max / 6.00 / - / -	21.00 Max	48.00 Max	42.00 Max	High Carbon Chrome Steel / Chrome Steel / PTFE Lined	21.00	Yes	
	<i>0.236</i>							<i>0.827</i>		

# Indicates item not stocked at time of printing - Please enquire for lead time

E&OE Pricing and all details subject to change without notice - Copyright Miniature Bearings Australia Pty Ltd

MBA Size Listings are a guide to sizes only and must not be solely relied on for critical design information.

## Rod Ends - Steel - Bronze Lined

Part Number	Eye Size (B) mm <i>inches</i>	Thread Size / Type mm <i>inches</i>	Widths (G/W/X/K) mm <i>inches</i>	Housing Dia. (D) mm <i>inches</i>	Height (H) mm <i>inches</i>	Centre Height (F) mm <i>inches</i>	Ball / Body / Seat	Thread Depth (A) mm <i>inches</i>	Grease Nipple	Static / Radial Load N
# CMM.00.06LH	6.00 <i>0.236</i>	M6 Male Left Hand	6.75 / 9.00 / - / -	20.00 <i>0.787</i>	46.00 <i>1.811</i>	36.00 <i>1.417</i>	High Carbon Chrome Steel / Chrome Steel / Bronze	21.00 <i>0.827</i>	No	2000 / 1000
# CFF.00.06LH	6.00 <i>0.236</i>	M6 Female Left Hand	6.75 / 9.00 / 14.00 / 13.00	20.00 <i>0.787</i>	40.00 <i>1.575</i>	30.00 <i>1.181</i>	High Carbon Chrome Steel / Chrome Steel / Bronze	12.00 <i>0.472</i>	No	
# CFF.00.06ss	6.00 <i>0.236</i>	M6 x 1.00 Female Right Hand	6.75 / 9.00 / 11.00 / 13.00	20.00 <i>0.787</i>	40.00 <i>1.575</i>	30.00 <i>1.181</i>	420 Stainless / 304 Stainless / Bronze	12.00 <i>0.472</i>	No	
# REM.06.00-L-B	6.00 <i>0.236</i>	M6 x 1.00 Male Left Hand	7.00 / 9.00 / - / -	18.00 <i>0.709</i>	45.00 <i>1.772</i>	36.00 <i>1.417</i>	High Carbon Chrome Steel / Chrome Steel / Bronze	22.00 <i>0.866</i>	No	2000 / 1000
REM.06.00-R-B-G	6.00 <i>0.236</i>	M6 x 1.00 Male Right Hand	7.00 / 9.00 / - / -	18.00 <i>0.709</i>	45.00 <i>1.772</i>	36.00 <i>1.417</i>	High Carbon Chrome Steel / Chrome Steel / Bronze	22.00 <i>0.866</i>	Yes	
REF.06.00-R-B-G	6.00 <i>0.236</i>	M6 x 1.00 Female Right Hand	7.00 / 9.00 / 11.00 / 13.00	18.00 <i>0.709</i>	39.00 <i>1.535</i>	30.00 <i>1.181</i>	High Carbon Chrome Steel / Chrome Steel / Bronze	14.00 <i>0.551</i>	Yes	

# Indicates item not stocked at time of printing - Please enquire for lead time

E&OE Pricing and all details subject to change without notice - Copyright Miniature Bearings Australia Pty Ltd

MBA Size Listings are a guide to sizes only and must not be solely relied on for critical design information.

## Rod Ends - Steel - Bronze Lined

Part Number	Eye Size (B) mm  <i>inches</i>	Thread Size / Type mm  <i>inches</i>	Widths (G/W/X/K) mm  <i>inches</i>	Housing Dia. (D) mm  <i>inches</i>	Height (H) mm  <i>inches</i>	Centre Height (F) mm  <i>inches</i>	Ball / Body / Seat	Thread Depth (A) mm  <i>inches</i>	Grease Nipple	Static / Radial Load N
# REF-06.35-R-B-G	6.35  <i>0.250</i>	1/4-28 UNF Female Right Hand	7.14 / 9.53 / 9.53 / 11.89	19.05  <i>0.750</i>	42.85  <i>1.687</i>	33.32  <i>1.312</i>	High Carbon Chrome Steel / Chrome Steel / Bronze	19.05  <i>0.750</i>	Yes	
# REF-06.35-L-B-G	6.35  <i>0.250</i>	1/4-28 UNF Female Left Hand	7.14 / 9.53 / 9.53 / 11.89	19.05  <i>0.750</i>	42.85  <i>1.687</i>	33.32  <i>1.312</i>	High Carbon Chrome Steel / Chrome Steel / Bronze	19.05  <i>0.750</i>	Yes	
# REM-06.35-L-B-G	6.35  <i>0.250</i>	1/4-28 UNF Male Left Hand	7.14 / 9.53 / - / -	19.05  <i>0.750</i>	49.20  <i>1.937</i>	39.67  <i>1.562</i>	High Carbon Chrome Steel / Chrome Steel / Bronze	25.40  <i>1.000</i>	Yes	
# REM-06.35-R-B-G	6.35  <i>0.250</i>	1/4-28 UNF Male Right Hand	7.14 / 9.53 / - / -	19.05  <i>0.750</i>	49.20  <i>1.937</i>	39.67  <i>1.562</i>	High Carbon Chrome Steel / Chrome Steel / Bronze	25.40  <i>1.000</i>	Yes	
REM-07.94-R-B-G	7.94  <i>0.313</i>	5/16-24 UNF Male Right Hand	8.74 / 11.10 / - / -	22.23  <i>0.875</i>	58.72  <i>2.312</i>	47.63  <i>1.875</i>	High Carbon Chrome Steel / Chrome Steel / Bronze	31.75  <i>1.250</i>	Yes	
# REF-07.94-R-B-G	7.94  <i>0.313</i>	5/16-24 UNF Female Right Hand	8.74 / 11.10 / 11.10 / 12.70	22.23  <i>0.875</i>	46.02  <i>1.812</i>	34.93  <i>1.375</i>	High Carbon Chrome Steel / Chrome Steel / Bronze	19.05  <i>0.750</i>	Yes	

# Indicates item not stocked at time of printing - Please enquire for lead time

E&OE Pricing and all details subject to change without notice - Copyright Miniature Bearings Australia Pty Ltd

MBA Size Listings are a guide to sizes only and must not be solely relied on for critical design information.

## Rod Ends - Steel - Bronze Lined

Part Number	Eye Size (B) mm  <i>inches</i>	Thread Size / Type mm  <i>inches</i>	Widths (G/W/X/K) mm  <i>inches</i>	Housing Dia. (D) mm  <i>inches</i>	Height (H) mm  <i>inches</i>	Centre Height (F) mm  <i>inches</i>	Ball / Body / Seat	Thread Depth (A) mm  <i>inches</i>	Grease Nipple	Static / Radial Load N
# REF-07.94-L-B-G	7.94  <i>0.313</i>	5/16-24 UNF Female Left Hand	8.74 / 11.10 / 11.10 / 12.70	22.23  <i>0.875</i>	46.02  <i>1.812</i>	34.93  <i>1.375</i>	High Carbon Chrome Steel / Chrome Steel / Bronze	19.05  <i>0.750</i>	Yes	
# REM-07.94-L-B-G	7.94  <i>0.313</i>	5/16-24 UNF Male Left Hand	8.74 / 11.10 / - / -	22.23  <i>0.875</i>	58.72  <i>2.312</i>	47.63  <i>1.875</i>	High Carbon Chrome Steel / Chrome Steel / Bronze	31.75  <i>1.250</i>	Yes	
# CFF.00.08ss	8.00  <i>0.315</i>	M8 x 1.25 Female Right Hand	9.00 / 12.00 / 14.00 / 16.00	24.00  <i>0.945</i>	48.00  <i>1.890</i>	36.00  <i>1.417</i>	420 Stainless / 304 Stainless / Bronze	16.00  <i>0.630</i>	No	
REF-08.00-L-B-G	8.00  <i>0.315</i>	M8 x 1.25 Female Left Hand	9.00 / 12.00 / 14.00 / 16.00	22.00  <i>0.866</i>	47.00  <i>1.850</i>	36.00  <i>1.417</i>	High Carbon Chrome Steel / Chrome Steel / Bronze	17.00  <i>0.669</i>	Yes	
# REF-08.00-R-B-G	8.00  <i>0.315</i>	M8 x 1.25 Female Right Hand	9.00 / 12.00 / 14.00 / 16.00	22.00  <i>0.866</i>	47.00  <i>1.850</i>	36.00  <i>1.417</i>	High Carbon Chrome Steel / Chrome Steel / Bronze	17.00  <i>0.669</i>	Yes	
REM-08.00-L-B-G	8.00  <i>0.315</i>	M8 x 1.25 Male Left Hand	9.00 / 12.00 / - / -	22.00  <i>0.866</i>	53.00  <i>2.087</i>	42.00  <i>1.654</i>	High Carbon Chrome Steel / Chrome Steel / Bronze	25.00  <i>0.984</i>	Yes	

# Indicates item not stocked at time of printing - Please enquire for lead time

E&OE Pricing and all details subject to change without notice - Copyright Miniature Bearings Australia Pty Ltd

MBA Size Listings are a guide to sizes only and must not be solely relied on for critical design information.

## Rod Ends - Steel - Bronze Lined

Part Number	Eye Size (B) mm <i>inches</i>	Thread Size / Type mm <i>inches</i>	Widths (G/W/X/K) mm <i>inches</i>	Housing Dia. (D) mm <i>inches</i>	Height (H) mm <i>inches</i>	Centre Height (F) mm <i>inches</i>	Ball / Body / Seat	Thread Depth (A) mm <i>inches</i>	Grease Nipple	Static / Radial Load N
REM-08.00-R-B-G	8.00 <i>0.315</i>	M8 x 1.25 Male Right Hand	9.00 / 12.00 / - / -	22.00 <i>0.866</i>	53.00 <i>2.087</i>	42.00 <i>1.654</i>	High Carbon Chrome Steel / Chrome Steel / Bronze	25.00 <i>0.984</i>	Yes	
# REF-09.52-R-B-G	9.53 <i>0.375</i>	3/8-24 UNF Female Right Hand	10.31 / 12.70 / 14.27 / 17.45	25.40 <i>1.000</i>	53.98 <i>2.125</i>	41.28 <i>1.625</i>	High Carbon Chrome Steel / Chrome Steel / Bronze	23.80 <i>0.937</i>	Yes	
# REM-09.52-L-B-G	9.53 <i>0.375</i>	3/8-24 UNF Male Left Hand	10.31 / 12.70 / - / -	25.40 <i>1.000</i>	61.93 <i>2.438</i>	49.23 <i>1.938</i>	High Carbon Chrome Steel / Chrome Steel / Bronze	31.75 <i>1.250</i>	Yes	
REM-09.52-R-B-G	9.53 <i>0.375</i>	3/8-24 UNF Male Right Hand	10.31 / 12.70 / - / -	25.40 <i>1.000</i>	61.93 <i>2.438</i>	49.23 <i>1.938</i>	High Carbon Chrome Steel / Chrome Steel / Bronze	31.75 <i>1.250</i>	Yes	
# REF-09.52-L-B-G	9.53 <i>0.375</i>	3/8-24 UNF Female Left Hand	10.31 / 12.70 / 14.27 / 17.45	25.40 <i>1.000</i>	53.98 <i>2.125</i>	41.28 <i>1.625</i>	High Carbon Chrome Steel / Chrome Steel / Bronze	23.80 <i>0.937</i>	Yes	
# CFF10x1.25	10.00 <i>0.394</i>	M10 x 1.25 Female Right Hand	10.50 / 14.00 / 17.00 / 19.00	28.00 <i>1.102</i>	57.00 <i>2.244</i>	43.00 <i>1.693</i>	High Carbon Chrome Steel / Chrome Steel / Bronze	20.00 <i>0.787</i>	No	

# Indicates item not stocked at time of printing - Please enquire for lead time

E&OE Pricing and all details subject to change without notice - Copyright Miniature Bearings Australia Pty Ltd

MBA Size Listings are a guide to sizes only and must not be solely relied on for critical design information.

## Rod Ends - Steel - Bronze Lined

Part Number	Eye Size (B) mm <i>inches</i>	Thread Size / Type mm <i>inches</i>	Widths (G/W/X/K) mm <i>inches</i>	Housing Dia. (D) mm <i>inches</i>	Height (H) mm <i>inches</i>	Centre Height (F) mm <i>inches</i>	Ball / Body / Seat	Thread Depth (A) mm <i>inches</i>	Grease Nipple	Static / Radial Load N
# CFF.00.10ss	10.00 <i>0.394</i>	M10 x 1.50 Female Right Hand	10.50 / 12.90 / 17.00 / 19.00	28.00 <i>1.102</i>	57.00 <i>2.244</i>	43.00 <i>1.693</i>	420 Stainless / 304 Stainless / Bronze	20.00 <i>0.787</i>	No	
REF-10.00-R-B-G	10.00 <i>0.394</i>	M10 x 1.50 Female Right Hand	11.00 / 14.00 / 17.00 / 19.00	26.00 <i>1.024</i>	56.00 <i>2.205</i>	43.00 <i>1.693</i>	High Carbon Chrome Steel / Chrome Steel / Bronze	21.00 <i>0.827</i>	Yes	
REF-10.00-L-B-G	10.00 <i>0.394</i>	M10 x 1.50 Female Left Hand	11.00 / 14.00 / 17.00 / 19.00	26.00 <i>1.024</i>	56.00 <i>2.205</i>	43.00 <i>1.693</i>	High Carbon Chrome Steel / Chrome Steel / Bronze	21.00 <i>0.827</i>	Yes	
REM-10.00-R-B-G	10.00 <i>0.394</i>	M10 x 1.50 Male Right Hand	11.00 / 14.00 / - / -	26.00 <i>1.024</i>	61.00 <i>2.402</i>	48.00 <i>1.890</i>	High Carbon Chrome Steel / Chrome Steel / Bronze	29.00 <i>1.142</i>	Yes	
# REM-10.00-L-B-G	10.00 <i>0.394</i>	M10 x 1.50 Male Left Hand	11.00 / 14.00 / - / -	26.00 <i>1.024</i>	61.00 <i>2.402</i>	48.00 <i>1.890</i>	High Carbon Chrome Steel / Chrome Steel / Bronze	29.00 <i>1.142</i>	Yes	
# REF-11.11-R-B-G	11.11 <i>0.437</i>	7/16-20 UNF Female Right Hand	11.10 / 14.27 / 15.88 / 19.05	28.58 <i>1.125</i>	60.33 <i>2.375</i>	46.02 <i>1.812</i>	High Carbon Chrome Steel / Chrome Steel / Bronze	26.97 <i>1.062</i>	Yes	

# Indicates item not stocked at time of printing - Please enquire for lead time

E&OE Pricing and all details subject to change without notice - Copyright Miniature Bearings Australia Pty Ltd

MBA Size Listings are a guide to sizes only and must not be solely relied on for critical design information.

## Rod Ends - Steel - Bronze Lined

Part Number	Eye Size (B) mm  <i>inches</i>	Thread Size / Type mm  <i>inches</i>	Widths (G/W/X/K) mm  <i>inches</i>	Housing Dia. (D) mm  <i>inches</i>	Height (H) mm  <i>inches</i>	Centre Height (F) mm  <i>inches</i>	Ball / Body / Seat	Thread Depth (A) mm  <i>inches</i>	Grease Nipple	Static / Radial Load N
# REM-11.11-R-B-G	11.11  <i>0.437</i>	7/16-20 UNF Male Right Hand	11.10 / 14.27 / - / -	28.58  <i>1.125</i>	68.28  <i>2.688</i>	53.98  <i>2.125</i>	High Carbon Chrome Steel / Chrome Steel / Bronze	34.93  <i>1.375</i>	Yes	
# REM-11.11-L-B-G	11.11  <i>0.437</i>	7/16-20 UNF Male Left Hand	11.10 / 14.27 / - / -	28.58  <i>1.125</i>	68.28  <i>2.688</i>	53.98  <i>2.125</i>	High Carbon Chrome Steel / Chrome Steel / Bronze	34.93  <i>1.375</i>	Yes	
# REF-11.11-L-B-G	11.11  <i>0.437</i>	7/16-20 UNF Female Left Hand	11.10 / 14.27 / 15.88 / 19.05	28.58  <i>1.125</i>	60.33  <i>2.375</i>	46.02  <i>1.812</i>	High Carbon Chrome Steel / Chrome Steel / Bronze	26.97  <i>1.062</i>	Yes	
# REF-12.00-L-B-G	12.00  <i>0.472</i>	M12 x 1.75 Female Left Hand	12.00 / 16.00 / 19.00 / 22.00	30.00  <i>1.181</i>	65.00  <i>2.559</i>	50.00  <i>1.969</i>	High Carbon Chrome Steel / Chrome Steel / Bronze	24.00  <i>0.945</i>	Yes	
# REF-12.00-R-B-G	12.00  <i>0.472</i>	M12 x 1.75 Female Right Hand	12.00 / 16.00 / 19.00 / 22.00	30.00  <i>1.181</i>	65.00  <i>2.559</i>	50.00  <i>1.969</i>	High Carbon Chrome Steel / Chrome Steel / Bronze	24.00  <i>0.945</i>	Yes	
# REM-12.00-R-B-G	12.00  <i>0.472</i>	M12 x 1.75 Male Right Hand	12.00 / 16.00 / - / -	30.00  <i>1.181</i>	69.00  <i>2.717</i>	54.00  <i>2.126</i>	High Carbon Chrome Steel / Chrome Steel / Bronze	33.00  <i>1.299</i>	Yes	

# Indicates item not stocked at time of printing - Please enquire for lead time

E&OE Pricing and all details subject to change without notice - Copyright Miniature Bearings Australia Pty Ltd

MBA Size Listings are a guide to sizes only and must not be solely relied on for critical design information.

## Rod Ends - Steel - Bronze Lined

Part Number	Eye Size (B) mm <i>inches</i>	Thread Size / Type mm <i>inches</i>	Widths (G/W/X/K) mm <i>inches</i>	Housing Dia. (D) mm <i>inches</i>	Height (H) mm <i>inches</i>	Centre Height (F) mm <i>inches</i>	Ball / Body / Seat	Thread Depth (A) mm <i>inches</i>	Grease Nipple	Static / Radial Load N
# REM-12.00-L-B-G	12.00 <i>0.472</i>	M12 x 1.75 Male Left Hand <i>inches</i>	12.00 / 16.00 / - / - <i>inches</i>	30.00 <i>1.181</i>	69.00 <i>2.717</i>	54.00 <i>2.126</i>	High Carbon Chrome Steel / Chrome Steel / Bronze	33.00 <i>1.299</i>	Yes	
# CFF12x1.25	12.00 <i>0.472</i>	M12 x 1.25 Female Right Hand <i>inches</i>	12.00 / 16.00 / 19.00 / 22.00 <i>inches</i>	32.00 <i>1.260</i>	66.00 <i>2.598</i>	50.00 <i>1.969</i>	High Carbon Chrome Steel / Chrome Steel / Bronze	22.00 <i>0.866</i>	No	
# CFF.00.12ss	12.00 <i>0.472</i>	M12 x 1.75 Female Right Hand <i>inches</i>	12.00 / 16.00 / 19.00 / 22.00 <i>inches</i>	32.00 <i>1.260</i>	66.00 <i>2.598</i>	50.00 <i>1.969</i>	420 Stainless / 304 Stainless / Bronze	22.00 <i>0.866</i>	No	
# REF-12.70-L-B-G	12.70 <i>0.500</i>	1/2-20 UNF Female Left Hand <i>inches</i>	12.70 / 15.88 / 19.05 / 22.23 <i>inches</i>	33.32 <i>1.312</i>	70.64 <i>2.781</i>	53.98 <i>2.125</i>	High Carbon Chrome Steel / Chrome Steel / Bronze	30.15 <i>1.187</i>	Yes	
# REF-12.70-R-B-G	12.70 <i>0.500</i>	1/2-20 UNF Female Right Hand <i>inches</i>	12.70 / 15.88 / 19.05 / 22.23 <i>inches</i>	33.32 <i>1.312</i>	70.64 <i>2.781</i>	53.98 <i>2.125</i>	High Carbon Chrome Steel / Chrome Steel / Bronze	30.15 <i>1.187</i>	Yes	
# REM-12.70-L-B-G	12.70 <i>0.500</i>	1/2-20 UNF Male Left Hand <i>inches</i>	12.70 / 15.88 / - / - <i>inches</i>	33.32 <i>1.312</i>	78.59 <i>3.094</i>	61.93 <i>2.438</i>	High Carbon Chrome Steel / Chrome Steel / Bronze	38.10 <i>1.500</i>	Yes	

# Indicates item not stocked at time of printing - Please enquire for lead time

E&OE Pricing and all details subject to change without notice - Copyright Miniature Bearings Australia Pty Ltd

MBA Size Listings are a guide to sizes only and must not be solely relied on for critical design information.

## Rod Ends - Steel - Bronze Lined

Part Number	Eye Size (B) mm <i>inches</i>	Thread Size / Type mm <i>inches</i>	Widths (G/W/X/K) mm <i>inches</i>	Housing Dia. (D) mm <i>inches</i>	Height (H) mm <i>inches</i>	Centre Height (F) mm <i>inches</i>	Ball / Body / Seat	Thread Depth (A) mm <i>inches</i>	Grease Nipple	Static / Radial Load N
REM-12.70-R-B-G	12.70 <i>0.500</i>	1/2-20 UNF Male Right Hand	12.70 / 15.88 / - / -	33.32 <i>1.312</i>	78.59 <i>3.094</i>	61.93 <i>2.438</i>	High Carbon Chrome Steel / Chrome Steel / Bronze	38.10 <i>1.500</i>	Yes	
# REM-14.00-L-B-G	14.00 <i>0.551</i>	M14 x 2.00 Male Left Hand	14.00 / 19.00 / - / -	34.00 <i>1.339</i>	77.00 <i>3.031</i>	60.00 <i>2.362</i>	High Carbon Chrome Steel / Chrome Steel / Bronze	36.00 <i>1.417</i>	Yes	
# REM-14.00-R-B-G	14.00 <i>0.551</i>	M14 x 2.00 Male Right Hand	14.00 / 19.00 / - / -	34.00 <i>1.339</i>	77.00 <i>3.031</i>	60.00 <i>2.362</i>	High Carbon Chrome Steel / Chrome Steel / Bronze	36.00 <i>1.417</i>	Yes	
# REF-14.00-R-B-G	14.00 <i>0.551</i>	M14 x 2.00 Female Right Hand	14.00 / 19.00 / 22.00 / 25.00	34.00 <i>1.339</i>	74.00 <i>2.913</i>	57.00 <i>2.244</i>	High Carbon Chrome Steel / Chrome Steel / Bronze	27.00 <i>1.063</i>	Yes	
# REF-14.00-L-B-G	14.00 <i>0.551</i>	M14 x 2.00 Female Left Hand	14.00 / 19.00 / 22.00 / 25.00	34.00 <i>1.339</i>	74.00 <i>2.913</i>	57.00 <i>2.244</i>	High Carbon Chrome Steel / Chrome Steel / Bronze	27.00 <i>1.063</i>	Yes	
# REF-15.88-L-B-G	15.88 <i>0.625</i>	5/8-18 UNF Female Left Hand	14.27 / 19.05 / 22.23 / 25.40	38.10 <i>1.500</i>	82.55 <i>3.250</i>	63.50 <i>2.500</i>	High Carbon Chrome Steel / Chrome Steel / Bronze	38.10 <i>1.500</i>	Yes	

# Indicates item not stocked at time of printing - Please enquire for lead time

E&OE Pricing and all details subject to change without notice - Copyright Miniature Bearings Australia Pty Ltd

MBA Size Listings are a guide to sizes only and must not be solely relied on for critical design information.

## Rod Ends - Steel - Bronze Lined

Part Number	Eye Size (B) mm <i>inches</i>	Thread Size / Type mm <i>inches</i>	Widths (G/W/X/K) mm <i>inches</i>	Housing Dia. (D) mm <i>inches</i>	Height (H) mm <i>inches</i>	Centre Height (F) mm <i>inches</i>	Ball / Body / Seat	Thread Depth (A) mm <i>inches</i>	Grease Nipple	Static / Radial Load N
# REM-15.88-L-B-G	15.88 <i>0.625</i>	5/8-18 UNF Male Left Hand <i>inches</i>	14.27 / 19.05 / - / - <i>inches</i>	38.10 <i>1.500</i>	85.73 <i>3.375</i>	66.68 <i>2.625</i>	High Carbon Chrome Steel / Chrome Steel / Bronze	41.28 <i>1.625</i>	Yes	
# REM-15.88-R-B-G	15.88 <i>0.625</i>	5/8-18 UNF Male Right Hand <i>inches</i>	14.27 / 19.05 / - / - <i>inches</i>	38.10 <i>1.500</i>	85.73 <i>3.375</i>	66.68 <i>2.625</i>	High Carbon Chrome Steel / Chrome Steel / Bronze	41.28 <i>1.625</i>	Yes	
# REF-15.88-R-B-G	15.88 <i>0.625</i>	5/8-18 UNF Female Right Hand <i>inches</i>	14.27 / 19.05 / 22.23 / 25.40 <i>inches</i>	38.10 <i>1.500</i>	82.55 <i>3.250</i>	63.50 <i>2.500</i>	High Carbon Chrome Steel / Chrome Steel / Bronze	38.10 <i>1.500</i>	Yes	
# CFF16x1.5	16.00 <i>0.630</i>	M16 x 1.50 Female Right Hand <i>inches</i>	15.00 / 21.00 / 22.00 / 27.00 <i>inches</i>	42.00 <i>1.654</i>	85.00 <i>3.346</i>	64.00 <i>2.520</i>	High Carbon Chrome Steel / Chrome Steel / Bronze	28.00 <i>1.102</i>	No	
# REM-16.00-L-B-G	16.00 <i>0.630</i>	M16 x 2.00 Male Left Hand <i>inches</i>	15.00 / 21.00 / - / - <i>inches</i>	38.00 <i>1.496</i>	85.00 <i>3.346</i>	66.00 <i>2.598</i>	High Carbon Chrome Steel / Chrome Steel / Bronze	40.00 <i>1.575</i>	Yes	
# REM-16.00-R-B-G	16.00 <i>0.630</i>	M16 x 2.00 Male Right Hand <i>inches</i>	15.00 / 21.00 / - / - <i>inches</i>	38.00 <i>1.496</i>	85.00 <i>3.346</i>	66.00 <i>2.598</i>	High Carbon Chrome Steel / Chrome Steel / Bronze	40.00 <i>1.575</i>	Yes	

# Indicates item not stocked at time of printing - Please enquire for lead time

E&OE Pricing and all details subject to change without notice - Copyright Miniature Bearings Australia Pty Ltd

MBA Size Listings are a guide to sizes only and must not be solely relied on for critical design information.

## Rod Ends - Steel - Bronze Lined

Part Number	Eye Size (B) mm  <i>inches</i>	Thread Size / Type mm  <i>inches</i>	Widths (G/W/X/K) mm  <i>inches</i>	Housing Dia. (D) mm  <i>inches</i>	Height (H) mm  <i>inches</i>	Centre Height (F) mm  <i>inches</i>	Ball / Body / Seat	Thread Depth (A) mm  <i>inches</i>	Grease Nipple	Static / Radial Load N
# REF-16.00-L-B-G	16.00  <i>0.630</i>	M16 x 2.00 Female Left Hand	15.00 / 21.00 / 22.00 / 27.00	38.00  <i>1.496</i>	83.00  <i>3.268</i>	64.00  <i>2.520</i>	High Carbon Chrome Steel / Chrome Steel / Bronze	33.00  <i>1.299</i>	Yes	
# REF-16.00-R-B-G	16.00  <i>0.630</i>	M16 x 2.00 Female Right Hand	15.00 / 21.00 / 22.00 / 27.00	38.00  <i>1.496</i>	83.00  <i>3.268</i>	64.00  <i>2.520</i>	High Carbon Chrome Steel / Chrome Steel / Bronze	33.00  <i>1.299</i>	Yes	
# CFF.00.16ss	16.00  <i>0.630</i>	M16 x 2.00 Female Right Hand	15.00 / 21.00 / 22.00 / 27.00	42.00  <i>1.654</i>	85.00  <i>3.346</i>	64.00  <i>2.520</i>	420 Stainless / 304 Stainless / Bronze	28.00  <i>1.102</i>	No	
# REF-18.00-L-B-G	18.00  <i>0.709</i>	M18 x 1.50 Female Left Hand	17.00 / 23.00 / 27.00 / 31.00	42.00  <i>1.654</i>	92.00  <i>3.622</i>	71.00  <i>2.795</i>	High Carbon Chrome Steel / Chrome Steel / Bronze	36.00  <i>1.417</i>	Yes	
# REF-18.00-R-B-G	18.00  <i>0.709</i>	M18 x 1.50 Female Right Hand	17.00 / 23.00 / 27.00 / 31.00	42.00  <i>1.654</i>	92.00  <i>3.622</i>	71.00  <i>2.795</i>	High Carbon Chrome Steel / Chrome Steel / Bronze	36.00  <i>1.417</i>	Yes	
# REM-18.00-R-B-G	18.00  <i>0.709</i>	M18 x 1.50 Male Right Hand	17.00 / 23.00 / - / -	42.00  <i>1.654</i>	93.00  <i>3.661</i>	72.00  <i>2.835</i>	High Carbon Chrome Steel / Chrome Steel / Bronze	44.00  <i>1.732</i>	Yes	

# Indicates item not stocked at time of printing - Please enquire for lead time

E&OE Pricing and all details subject to change without notice - Copyright Miniature Bearings Australia Pty Ltd

MBA Size Listings are a guide to sizes only and must not be solely relied on for critical design information.

## Rod Ends - Steel - Bronze Lined

Part Number	Eye Size (B) mm <i>inches</i>	Thread Size / Type mm <i>inches</i>	Widths (G/W/X/K) mm <i>inches</i>	Housing Dia. (D) mm <i>inches</i>	Height (H) mm <i>inches</i>	Centre Height (F) mm <i>inches</i>	Ball / Body / Seat	Thread Depth (A) mm <i>inches</i>	Grease Nipple	Static / Radial Load N
# REM-18.00-L-B-G	18.00 <i>0.709</i>	M18 x 1.50 Male Left Hand <i>inches</i>	17.00 / 23.00 / - / - <i>inches</i>	42.00 <i>1.654</i>	93.00 <i>3.661</i>	72.00 <i>2.835</i>	High Carbon Chrome Steel / Chrome Steel / Bronze	44.00 <i>1.732</i>	Yes	
# REF-19.05-R-B-G	19.05 <i>0.750</i>	3/4-16 UNF Female Right Hand <i>inches</i>	17.45 / 22.23 / 25.40 / 28.58 <i>inches</i>	44.45 <i>1.750</i>	95.25 <i>3.750</i>	73.03 <i>2.875</i>	High Carbon Chrome Steel / Chrome Steel / Bronze	44.45 <i>1.750</i>	Yes	
# REF-19.05-L-B-G	19.05 <i>0.750</i>	3/4-16 UNF Female Left Hand <i>inches</i>	17.45 / 22.23 / 25.40 / 28.58 <i>inches</i>	44.45 <i>1.750</i>	95.25 <i>3.750</i>	73.03 <i>2.875</i>	High Carbon Chrome Steel / Chrome Steel / Bronze	44.45 <i>1.750</i>	Yes	
# REM-19.05-R-B-G	19.05 <i>0.750</i>	3/4-16 UNF Male Right Hand <i>inches</i>	17.45 / 22.23 / - / - <i>inches</i>	44.45 <i>1.750</i>	95.25 <i>3.750</i>	73.03 <i>2.875</i>	High Carbon Chrome Steel / Chrome Steel / Bronze	44.45 <i>1.750</i>	Yes	
# REM-19.05-L-B-G	19.05 <i>0.750</i>	3/4-16 UNF Male Left Hand <i>inches</i>	17.45 / 22.23 / - / - <i>inches</i>	44.45 <i>1.750</i>	95.25 <i>3.750</i>	73.03 <i>2.875</i>	High Carbon Chrome Steel / Chrome Steel / Bronze	44.45 <i>1.750</i>	Yes	
# REM-20.00-R-B-G	20.00 <i>0.787</i>	M20 x 1.50 Male Right Hand <i>inches</i>	18.00 / 25.00 / - / - <i>inches</i>	46.00 <i>1.811</i>	101.00 <i>3.976</i>	78.00 <i>3.071</i>	High Carbon Chrome Steel / Chrome Steel / Bronze	47.00 <i>1.850</i>	Yes	

# Indicates item not stocked at time of printing - Please enquire for lead time

E&OE Pricing and all details subject to change without notice - Copyright Miniature Bearings Australia Pty Ltd

MBA Size Listings are a guide to sizes only and must not be solely relied on for critical design information.

## Rod Ends - Steel - Bronze Lined

Part Number	Eye Size (B) mm <i>inches</i>	Thread Size / Type mm <i>inches</i>	Widths (G/W/X/K) mm <i>inches</i>	Housing Dia. (D) mm <i>inches</i>	Height (H) mm <i>inches</i>	Centre Height (F) mm <i>inches</i>	Ball / Body / Seat	Thread Depth (A) mm <i>inches</i>	Grease Nipple	Static / Radial Load N
# REM-20.00-L-B-G	20.00 <i>0.787</i>	M20 x 1.50 Male Left Hand <i>inches</i>	18.00 / 25.00 / - / - <i>inches</i>	46.00 <i>1.811</i>	101.00 <i>3.976</i>	78.00 <i>3.071</i>	High Carbon Chrome Steel / Chrome Steel / Bronze	47.00 <i>1.850</i>	Yes	
# CMM20x1.5	20.00 <i>0.787</i>	M20 x 1.50 Male Right Hand <i>inches</i>	18.00 <i>0.709</i>	50.00 <i>1.969</i>	103.00 <i>4.055</i>	78.00 <i>3.071</i>	High Carbon Chrome Steel / Chrome Steel / Bronze	45.00 <i>1.772</i>	No	
# REF-20.00-L-B-G	20.00 <i>0.787</i>	M20 x 1.50 Female Left Hand <i>inches</i>	18.00 / 25.00 / 32.00 / 37.00 <i>inches</i>	46.00 <i>1.811</i>	100.00 <i>3.937</i>	77.00 <i>3.031</i>	High Carbon Chrome Steel / Chrome Steel / Bronze	40.00 <i>1.575</i>	Yes	
# CFF.00.20ss	20.00 <i>0.787</i>	M20 x 2.50 Female Right Hand <i>inches</i>	18.00 / 25.00 / 30.00 / 34.00 <i>inches</i>	50.00 <i>1.969</i>	102.00 <i>4.016</i>	77.00 <i>3.031</i>	420 Stainless / 304 Stainless / Bronze	33.00 <i>1.299</i>	No	
# CMM20x1.5LH	20.00 <i>0.787</i>	M20 x 1.50 Male Left Hand <i>inches</i>	18.00 <i>0.709</i>	50.00 <i>1.969</i>	103.00 <i>4.055</i>	78.00 <i>3.071</i>	High Carbon Chrome Steel / Chrome Steel / Bronze	45.00 <i>1.772</i>	No	
# REF-20.00-R-B-G	20.00 <i>0.787</i>	M20 x 1.50 Female Right Hand <i>inches</i>	18.00 / 25.00 / 32.00 / 37.00 <i>inches</i>	46.00 <i>1.811</i>	100.00 <i>3.937</i>	77.00 <i>3.031</i>	High Carbon Chrome Steel / Chrome Steel / Bronze	40.00 <i>1.575</i>	Yes	

# Indicates item not stocked at time of printing - Please enquire for lead time

E&OE Pricing and all details subject to change without notice - Copyright Miniature Bearings Australia Pty Ltd

MBA Size Listings are a guide to sizes only and must not be solely relied on for critical design information.

## Rod Ends - Steel - Bronze Lined

Part Number	Eye Size (B) mm  <i>inches</i>	Thread Size / Type mm  <i>inches</i>	Widths (G/W/X/K) mm  <i>inches</i>	Housing Dia. (D) mm  <i>inches</i>	Height (H) mm  <i>inches</i>	Centre Height (F) mm  <i>inches</i>	Ball / Body / Seat	Thread Depth (A) mm  <i>inches</i>	Grease Nipple	Static / Radial Load N
# REF-22.00-R-B-G	22.00  <i>0.866</i>	M22 x 1.50 Female Right Hand	20.00 / 28.00 / 32.00 / 37.00	50.00  <i>1.969</i>	109.00  <i>4.291</i>	84.00  <i>3.307</i>	High Carbon Chrome Steel / Chrome Steel / Bronze	43.00  <i>1.693</i>	Yes	
# REM-22.00-L-B-G	22.00  <i>0.866</i>	M22 x 1.50 Male Left Hand	20.00 / 28.00 / - / -	50.00  <i>1.969</i>	109.00  <i>4.291</i>	84.00  <i>3.307</i>	High Carbon Chrome Steel / Chrome Steel / Bronze	51.00  <i>2.008</i>	Yes	
# REF-22.00-L-B-G	22.00  <i>0.866</i>	M22 x 1.50 Female Left Hand	20.00 / 28.00 / 32.00 / 37.00	50.00  <i>1.969</i>	109.00  <i>4.291</i>	84.00  <i>3.307</i>	High Carbon Chrome Steel / Chrome Steel / Bronze	43.00  <i>1.693</i>	Yes	
# REM-22.00-R-B-G	22.00  <i>0.866</i>	M22 x 1.50 Male Right Hand	20.00 / 28.00 / - / -	50.00  <i>1.969</i>	109.00  <i>4.291</i>	84.00  <i>3.307</i>	High Carbon Chrome Steel / Chrome Steel / Bronze	51.00  <i>2.008</i>	Yes	
# REF-25.00-R-B-G	25.00  <i>0.984</i>	M24 x 2.00 Female Right Hand	22.00 / 31.00 / 36.00 / 42.00	56.00  <i>2.205</i>	122.00  <i>4.803</i>	94.00  <i>3.701</i>	High Carbon Chrome Steel / Chrome Steel / Bronze	48.00  <i>1.890</i>	Yes	
# REF-25.00-L-B-G	25.00  <i>0.984</i>	M24 x 2.00 Female Left Hand	22.00 / 31.00 / 36.00 / 42.00	56.00  <i>2.205</i>	122.00  <i>4.803</i>	94.00  <i>3.701</i>	High Carbon Chrome Steel / Chrome Steel / Bronze	48.00  <i>1.890</i>	Yes	

# Indicates item not stocked at time of printing - Please enquire for lead time

E&OE Pricing and all details subject to change without notice - Copyright Miniature Bearings Australia Pty Ltd

MBA Size Listings are a guide to sizes only and must not be solely relied on for critical design information.

## Rod Ends - Steel - Bronze Lined

Part Number	Eye Size (B) mm <i>inches</i>	Thread Size / Type mm <i>inches</i>	Widths (G/W/X/K) mm <i>inches</i>	Housing Dia. (D) mm <i>inches</i>	Height (H) mm <i>inches</i>	Centre Height (F) mm <i>inches</i>	Ball / Body / Seat	Thread Depth (A) mm <i>inches</i>	Grease Nipple	Static / Radial Load N
# REM-25.00-L-B-G	25.00 <i>0.984</i>	M24 x 2.00 Male Left Hand <i>inches</i>	22.00 / 31.00 / - / - <i>inches</i>	56.00 <i>2.205</i>	122.00 <i>4.803</i>	94.00 <i>3.701</i>	High Carbon Chrome Steel / Chrome Steel / Bronze	57.00 <i>2.244</i>	Yes	
# REM-25.00-R-B-G	25.00 <i>0.984</i>	M24 x 2.00 Male Right Hand <i>inches</i>	22.00 / 31.00 / - / - <i>inches</i>	56.00 <i>2.205</i>	122.00 <i>4.803</i>	94.00 <i>3.701</i>	High Carbon Chrome Steel / Chrome Steel / Bronze	57.00 <i>2.244</i>	Yes	
# REF-25.40-L-B-G	25.40 <i>1.000</i>	1.1/4-12 UNF Female Left Hand <i>inches</i>	24.50 / 34.90 / 38.10 / 47.00 <i>inches</i>	67.00 <i>2.638</i>	143.50 <i>5.650</i>	110.00 <i>4.331</i>	High Carbon Chrome Steel / Chrome Steel / Bronze	55.30 <i>2.177</i>	Yes	
# REM-25.40-R-B-G	25.40 <i>1.000</i>	1.1/4-12 UNF Male Right Hand <i>inches</i>	24.50 / 34.90 / - / - <i>inches</i>	67.00 <i>2.638</i>	143.50 <i>5.650</i>	110.00 <i>4.331</i>	High Carbon Chrome Steel / Chrome Steel / Bronze	66.00 <i>2.598</i>	Yes	
# REF-25.40-R-B-G	25.40 <i>1.000</i>	1.1/4-12 UNF Female Right Hand <i>inches</i>	24.50 / 34.90 / 38.10 / 47.00 <i>inches</i>	67.00 <i>2.638</i>	143.50 <i>5.650</i>	110.00 <i>4.331</i>	High Carbon Chrome Steel / Chrome Steel / Bronze	55.30 <i>2.177</i>	Yes	
# REM-25.40-L-B-G	25.40 <i>1.000</i>	1.1/4-12 UNF Male Left Hand <i>inches</i>	24.50 / 34.90 / - / - <i>inches</i>	67.00 <i>2.638</i>	143.50 <i>5.650</i>	110.00 <i>4.331</i>	High Carbon Chrome Steel / Chrome Steel / Bronze	66.00 <i>2.598</i>	Yes	

# Indicates item not stocked at time of printing - Please enquire for lead time

E&OE Pricing and all details subject to change without notice - Copyright Miniature Bearings Australia Pty Ltd

MBA Size Listings are a guide to sizes only and must not be solely relied on for critical design information.

## Rod Ends - Steel - Bronze Lined

Part Number	Eye Size (B) mm <i>inches</i>	Thread Size / Type mm <i>inches</i>	Widths (G/W/X/K) mm <i>inches</i>	Housing Dia. (D) mm <i>inches</i>	Height (H) mm <i>inches</i>	Centre Height (F) mm <i>inches</i>	Ball / Body / Seat	Thread Depth (A) mm <i>inches</i>	Grease Nipple	Static / Radial Load N
# CFF27x2	30.00	M27 x 2.00 Female Right Hand	25.00 / 37.00 / 41.00 / 50.00	70.00	145.00	110.00	High Carbon Chrome Steel / Chrome Steel / Bronze	51.00	No	
	<i>1.181</i>			<i>2.756</i>	<i>5.709</i>	<i>4.331</i>		<i>2.008</i>		
# CFF30x2	30.00	M30 x 2.00 Female Right Hand	25.00 / 37.00 / 41.00 / 50.00	70.00	145.00	110.00	High Carbon Chrome Steel / Chrome Steel / Bronze	51.00	No	
	<i>1.181</i>			<i>2.756</i>	<i>5.709</i>	<i>4.331</i>		<i>2.008</i>		
# REM-30.00-L-B-G	30.00	M30 x 2.00 Male Left Hand	26.00 / 37.00 / - / -	67.00	143.50	110.00	High Carbon Chrome Steel / Chrome Steel / Bronze	66.00	Yes	
	<i>1.181</i>			<i>2.638</i>	<i>5.650</i>	<i>4.331</i>		<i>2.598</i>		
# REF-30.00-L-B-G	30.00	M30 x 2.00 Female Left Hand	26.00 / 37.00 / 41.00 / 50.00	67.00	143.50	110.00	High Carbon Chrome Steel / Chrome Steel / Bronze	56.00	Yes	
	<i>1.181</i>			<i>2.638</i>	<i>5.650</i>	<i>4.331</i>		<i>2.205</i>		
# REM-30.00-R-B-G	30.00	M30 x 2.00 Male Right Hand	26.00 / 37.00 / - / -	67.00	143.50	110.00	High Carbon Chrome Steel / Chrome Steel / Bronze	66.00	Yes	
	<i>1.181</i>			<i>2.638</i>	<i>5.650</i>	<i>4.331</i>		<i>2.598</i>		
# REF-30.00-R-B-G	30.00	M30 x 2.00 Female Right Hand	26.00 / 37.00 / 41.00 / 50.00	67.00	143.50	110.00	High Carbon Chrome Steel / Chrome Steel / Bronze	56.00	Yes	
	<i>1.181</i>			<i>2.638</i>	<i>5.650</i>	<i>4.331</i>		<i>2.205</i>		

# Indicates item not stocked at time of printing - Please enquire for lead time

E&OE Pricing and all details subject to change without notice - Copyright Miniature Bearings Australia Pty Ltd

MBA Size Listings are a guide to sizes only and must not be solely relied on for critical design information.

## Rod Ends - Steel - Bronze Lined

Part Number	Eye Size (B) mm	Thread Size / Type mm	Widths (G/W/X/K) mm	Housing Dia. (D) mm	Height (H) mm	Centre Height (F) mm	Ball / Body / Seat	Thread Depth (A) mm	Grease Nipple	Static / Radial Load N
	<i>inches</i>	<i>inches</i>	<i>inches</i>	<i>inches</i>	<i>inches</i>	<i>inches</i>		<i>inches</i>		
# CFF36x2	35.00	M36 x 2.00 Female Right Hand	28.00 / 43.00 / 50.00 / 58.00	80.00	165.00	125.00	High Carbon Chrome Steel / Chrome Steel / Bronze	56.00	No	
	<i>1.378</i>			<i>3.150</i>	<i>6.496</i>	<i>4.921</i>		<i>2.205</i>		

# Indicates item not stocked at time of printing - Please enquire for lead time

E&OE Pricing and all details subject to change without notice - Copyright Miniature Bearings Australia Pty Ltd

MBA Size Listings are a guide to sizes only and must not be solely relied on for critical design information.



DISTRIBUTED BY

Ask us to put your name and address here

<http://www.minibearings.com.au/product>

Ph +61 7 3245 7977

Fax +61 7 3245 1017

Catalogue requests to [catalogues@minibearings.com.au](mailto:catalogues@minibearings.com.au)
