



MBA

Worms and Worm Gears - 48 Pitch (Series 1) - Metallic

Worms and Gears must be chosen from the same pitch and series to match.

14.5 Degree Pressure Angle - 3.35 Degree Lead Angle - 1 Lead. Includes anti-backlash series.

A single start worm and gear will provide a ratio equivalent to the number of teeth on the gear.

A double start worm and gear will provide a ratio of half the number of teeth on the gear.

Worms are shown in the table following the gears. This may not be on the same page.

Worms and Gears in this category match each other if the thread direction is the same.

GEARS

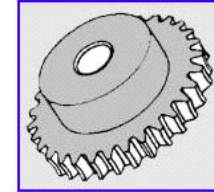
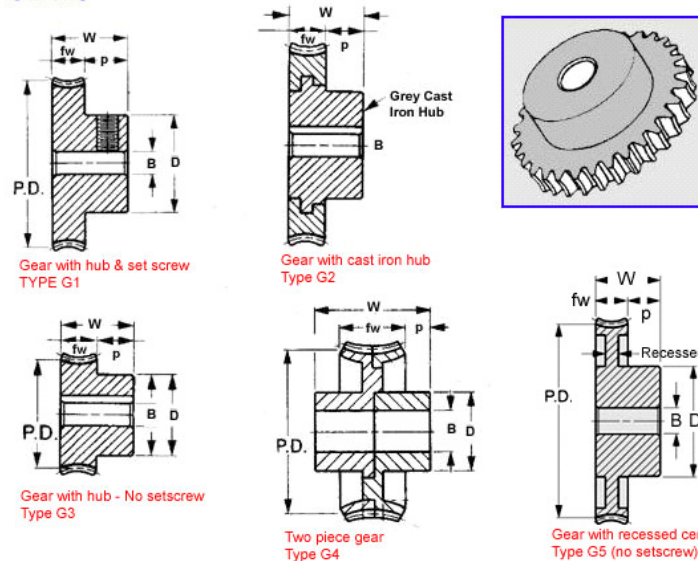

WORMS

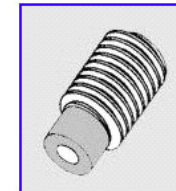
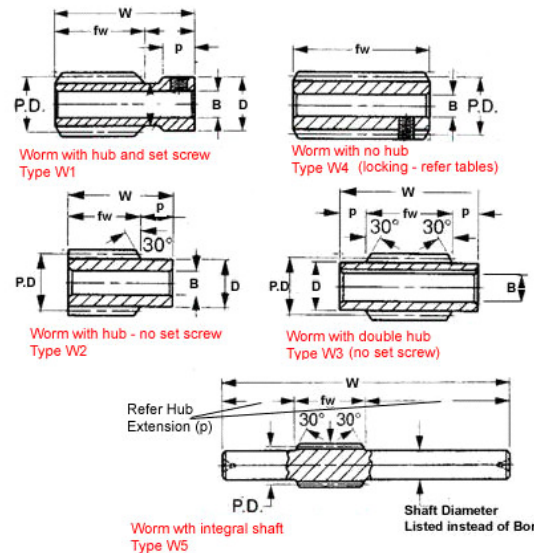

Worms and Worm Gears - 48 Pitch (Series 1) - Metallic

Part Number	Gear or Worm	Teeth / PCD (No. / mm)	Direction	Starts / Type	Bore (B) mm <i>inches</i>	Overall Width or Length (w) mm <i>inches</i>	Face Width (fw) mm <i>inches</i>	Hub Diameter (D) / Lock Method mm <i>inches</i>	Quality / Material	Hub Projection (p) mm <i>inches</i>
WG1R48-1-030-05HS0476-BRZ	Gear with Hub	30 / 15.88	Right Hand	Single / Type G1	4.757 <i>0.187</i>	10.351 <i>0.408</i>	4.762 <i>0.187</i>	9.52 / Set Screw	AGMA Q10 / Bronze	5.59 <i>0.220</i>
# WG1R48-1-030-05HS0317-BRZ	Gear with Hub	30 / 15.88	Right Hand	Single / Type G1	3.170 <i>0.125</i>	10.351 <i>0.408</i>	4.762 <i>0.187</i>	7.92 / Set Screw	AGMA Q10 / Bronze	5.59 <i>0.220</i>
# WG1R48-1-030-05HS0635-BRZ	Gear with Hub	30 / 15.88	Right Hand	Single / Type G1	6.345 <i>0.250</i>	10.351 <i>0.408</i>	4.762 <i>0.187</i>	12.70 / Set Screw	AGMA Q10 / Bronze	5.59 <i>0.220</i>
# WG1R48-1-035-05HS0317-BRZ	Gear with Hub	35 / 18.52	Right Hand	Single / Type G1	3.170 <i>0.125</i>	10.351 <i>0.408</i>	4.762 <i>0.187</i>	7.92 / Set Screw	AGMA Q10 / Bronze	5.59 <i>0.220</i>
# WG1R48-1-035-05HS0476-BRZ	Gear with Hub	35 / 18.52	Right Hand	Single / Type G1	4.757 <i>0.187</i>	10.351 <i>0.408</i>	4.762 <i>0.187</i>	9.52 / Set Screw	AGMA Q10 / Bronze	5.59 <i>0.220</i>

Indicates item not stocked at time of printing - Please enquire for lead time

E&OE Pricing and all details subject to change without notice - Copyright Miniature Bearings Australia Pty Ltd

MBA Size Listings are a guide to sizes only and must not be solely relied on for critical design information.

Worms and Worm Gears - 48 Pitch (Series 1) - Metallic

Part Number	Gear or Worm	Teeth / PCD (No. / mm)	Direction	Starts / Type	Bore (B) mm	Overall Width or Length (w) mm	Face Width (fw) mm	Hub Diameter (D) / Lock Method mm	Quality / Material	Hub Projection (p) mm
					<i>inches</i>	<i>inches</i>	<i>inches</i>	<i>inches</i>		<i>inches</i>
# WG1R48-1-035-05HS0635-BRZ	Gear with Hub	35 / 18.52	Right Hand	Single / Type G1	6.345	10.351	4.762	12.70 / Set Screw	AGMA Q10 / Bronze	5.59
					<i>0.250</i>	<i>0.408</i>	<i>0.187</i>			<i>0.220</i>
# WG1R48-1-040-05HS0635-BRZ	Gear with Hub	40 / 21.17	Right Hand	Single / Type G1	6.345	10.351	4.762	12.70 / Set Screw	AGMA Q10 / Bronze	5.59
					<i>0.250</i>	<i>0.408</i>	<i>0.187</i>			<i>0.220</i>
WG1R48-1-040-05HS0317-BRZ	Gear with Hub	40 / 21.17	Right Hand	Single / Type G1	3.170	10.351	4.762	7.92 / Set Screw	AGMA Q10 / Bronze	5.59
					<i>0.125</i>	<i>0.408</i>	<i>0.187</i>			<i>0.220</i>
# WG1R48-1-040-05HS0476-BRZ	Gear with Hub	40 / 21.17	Right Hand	Single / Type G1	4.757	10.351	4.762	9.52 / Set Screw	AGMA Q10 / Bronze	5.59
					<i>0.187</i>	<i>0.408</i>	<i>0.187</i>			<i>0.220</i>
WG1R48-1-045-05HS0635-BRZ	Gear with Hub	45 / 23.81	Right Hand	Single / Type G1	6.345	10.351	4.762	12.70 / Set Screw	AGMA Q10 / Bronze	5.59
					<i>0.250</i>	<i>0.408</i>	<i>0.187</i>			<i>0.220</i>
# WG1R48-1-045-05HS0317-BRZ	Gear with Hub	45 / 23.81	Right Hand	Single / Type G1	3.170	10.351	4.762	7.92 / Set Screw	AGMA Q10 / Bronze	5.59
					<i>0.125</i>	<i>0.408</i>	<i>0.187</i>			<i>0.220</i>
# WG1R48-1-045-05HS0476-BRZ	Gear with Hub	45 / 23.81	Right Hand	Single / Type G1	4.757	10.351	4.762	9.52 / Set Screw	AGMA Q10 / Bronze	5.59
					<i>0.187</i>	<i>0.408</i>	<i>0.187</i>			<i>0.220</i>
# WG1R48-1-050-05HS0476-BRZ	Gear with Hub	50 / 26.46	Right Hand	Single / Type G1	4.757	10.351	4.762	9.52 / Set Screw	AGMA Q10 / Bronze	5.59
					<i>0.187</i>	<i>0.408</i>	<i>0.187</i>			<i>0.220</i>

Indicates item not stocked at time of printing - Please enquire for lead time

E&OE Pricing and all details subject to change without notice - Copyright Miniature Bearings Australia Pty Ltd

MBA Size Listings are a guide to sizes only and must not be solely relied on for critical design information.

Worms and Worm Gears - 48 Pitch (Series 1) - Metallic

Part Number	Gear or Worm	Teeth / PCD (No. / mm)	Direction	Starts / Type	Bore (B) mm	Overall Width or Length (w) mm	Face Width (fw) mm	Hub Diameter (D) / Lock Method mm	Quality / Material	Hub Projection (p) mm
					<i>inches</i>	<i>inches</i>	<i>inches</i>	<i>inches</i>		<i>inches</i>
# WG1R48-1-050-05HS0317-BRZ	Gear with Hub	50 / 26.46	Right Hand	Single / Type G1	3.170 <i>0.125</i>	10.351 <i>0.408</i>	4.762 <i>0.187</i>	7.92 / Set Screw	AGMA Q10 / Bronze	5.59 <i>0.220</i>
# WG1R48-1-050-05HS0635-BRZ	Gear with Hub	50 / 26.46	Right Hand	Single / Type G1	6.345 <i>0.250</i>	10.351 <i>0.408</i>	4.762 <i>0.187</i>	12.70 / Set Screw	AGMA Q10 / Bronze	5.59 <i>0.220</i>
# WG1R48-1-055-05HS0476-BRZ	Gear with Hub	55 / 29.11	Right Hand	Single / Type G1	4.757 <i>0.187</i>	10.351 <i>0.408</i>	4.762 <i>0.187</i>	9.52 / Set Screw	AGMA Q10 / Bronze	5.59 <i>0.220</i>
# WG1R48-1-055-05HS0635-BRZ	Gear with Hub	55 / 29.11	Right Hand	Single / Type G1	6.345 <i>0.250</i>	10.351 <i>0.408</i>	4.762 <i>0.187</i>	12.70 / Set Screw	AGMA Q10 / Bronze	5.59 <i>0.220</i>
# WG1R48-1-055-05HS0317-BRZ	Gear with Hub	55 / 29.11	Right Hand	Single / Type G1	3.170 <i>0.125</i>	10.351 <i>0.408</i>	4.762 <i>0.187</i>	7.92 / Set Screw	AGMA Q10 / Bronze	5.59 <i>0.220</i>
# WG1R48-1-060-05HS0635-BRZ	Gear with Hub	60 / 31.75	Right Hand	Single / Type G1	6.345 <i>0.250</i>	10.351 <i>0.408</i>	4.762 <i>0.187</i>	12.70 / Set Screw	AGMA Q10 / Bronze	5.59 <i>0.220</i>
# WG1R48-1-060-05HS0317-BRZ	Gear with Hub	60 / 31.75	Right Hand	Single / Type G1	3.170 <i>0.125</i>	10.351 <i>0.408</i>	4.762 <i>0.187</i>	7.92 / Set Screw	AGMA Q10 / Bronze	5.59 <i>0.220</i>
# WG1R48-1-060-05HS0476-BRZ	Gear with Hub	60 / 31.75	Right Hand	Single / Type G1	4.757 <i>0.187</i>	10.351 <i>0.408</i>	4.762 <i>0.187</i>	9.52 / Set Screw	AGMA Q10 / Bronze	5.59 <i>0.220</i>

Indicates item not stocked at time of printing - Please enquire for lead time

E&OE Pricing and all details subject to change without notice - Copyright Miniature Bearings Australia Pty Ltd

MBA Size Listings are a guide to sizes only and must not be solely relied on for critical design information.

Worms and Worm Gears - 48 Pitch (Series 1) - Metallic

Part Number	Gear or Worm	Teeth / PCD (No. / mm)	Direction	Starts / Type	Bore (B) mm	Overall Width or Length (w) mm	Face Width (fw) mm	Hub Diameter (D) / Lock Method mm	Quality / Material	Hub Projection (p) mm
					<i>inches</i>	<i>inches</i>	<i>inches</i>	<i>inches</i>		<i>inches</i>
# WG1R48-1-065-05HS0317-BRZ	Gear with Hub	65 / 34.39	Right Hand	Single / Type G1	3.170 <i>0.125</i>	10.351 <i>0.408</i>	4.762 <i>0.187</i>	7.92 / Set Screw	AGMA Q10 / Bronze	5.59 <i>0.220</i>
# WG1R48-1-065-05HS0635-BRZ	Gear with Hub	65 / 34.39	Right Hand	Single / Type G1	6.345 <i>0.250</i>	10.351 <i>0.408</i>	4.762 <i>0.187</i>	12.70 / Set Screw	AGMA Q10 / Bronze	5.59 <i>0.220</i>
# WG1R48-1-065-05HS0476-BRZ	Gear with Hub	65 / 34.39	Right Hand	Single / Type G1	4.757 <i>0.187</i>	10.351 <i>0.408</i>	4.762 <i>0.187</i>	9.52 / Set Screw	AGMA Q10 / Bronze	5.59 <i>0.220</i>
# WG1R48-1-070-05HS0317-BRZ	Gear with Hub	70 / 37.04	Right Hand	Single / Type G1	3.170 <i>0.125</i>	10.351 <i>0.408</i>	4.762 <i>0.187</i>	7.92 / Set Screw	AGMA Q10 / Bronze	5.59 <i>0.220</i>
# WG1R48-1A-070-05HC0317-BRZ	Gear with Hub - Antibacklash	70 / 37.04	Right Hand / Antibacklash	Single / Type Not Shown	3.169 <i>0.125</i>	10.846 <i>0.427</i>	4.762 <i>0.187</i>	Clamp Hub / 4.76	AGMA 10 / Bronze with 302 Stainless Hub and Springs	6.08 <i>0.239</i>
# WG1R48-1-070-05HS0635-BRZ	Gear with Hub	70 / 37.04	Right Hand	Single / Type G1	6.345 <i>0.250</i>	10.351 <i>0.408</i>	4.762 <i>0.187</i>	12.70 / Set Screw	AGMA Q10 / Bronze	5.59 <i>0.220</i>
# WG1R48-1A-070-05HS0476-BRZ	Gear with Hub - Antibacklash	70 / 37.04	Right Hand / Antibacklash	Single / Type G3	4.757 <i>0.187</i>	10.846 <i>0.427</i>	4.762 <i>0.187</i>	Pin Hub and Set Screw / 9.52	AGMA 10 / Bronze with 302 Stainless Hub and Springs	6.08 <i>0.239</i>

Indicates item not stocked at time of printing - Please enquire for lead time

E&OE Pricing and all details subject to change without notice - Copyright Miniature Bearings Australia Pty Ltd

MBA Size Listings are a guide to sizes only and must not be solely relied on for critical design information.

Worms and Worm Gears - 48 Pitch (Series 1) - Metallic

Part Number	Gear or Worm	Teeth / PCD (No. / mm)	Direction	Starts / Type	Bore (B) mm	Overall Width or Length (w) mm	Face Width (fw) mm	Hub Diameter (D) / Lock Method mm	Quality / Material	Hub Projection (p) mm
					<i>inches</i>	<i>inches</i>	<i>inches</i>	<i>inches</i>		<i>inches</i>
# WG1R48-1A-070-05HC0635-BRZ	Gear with Hub - Antibacklash	70 / 37.04	Right Hand / Antibacklash	Single / Type Not Shown	6.345	10.846	4.762	Clamp Hub / 7.92	AGMA 10 / Bronze with 302 Stainless Hub and Springs	6.08
					<i>0.250</i>	<i>0.427</i>	<i>0.187</i>			<i>0.239</i>
# WG1R48-1A-070-05HC0476-BRZ	Gear with Hub - Antibacklash	70 / 37.04	Right Hand / Antibacklash	Single / Type Not Shown	4.757	10.846	4.762	Clamp Hub / 6.35	AGMA 10 / Bronze with 302 Stainless Hub and Springs	6.08
					<i>0.187</i>	<i>0.427</i>	<i>0.187</i>			<i>0.239</i>
# WG1R48-1A-070-05HS0317-BRZ	Gear with Hub - Antibacklash	70 / 37.04	Right Hand / Antibacklash	Single / Type G3	3.169	10.846	4.762	Pin Hub and Set Screw / 7.92	AGMA 10 / Bronze with 302 Stainless Hub and Springs	6.08
					<i>0.125</i>	<i>0.427</i>	<i>0.187</i>			<i>0.239</i>
# WG1R48-1A-070-05HS0635-BRZ	Gear with Hub - Antibacklash	70 / 37.04	Right Hand / Antibacklash	Single / Type G3	6.345	10.846	4.762	Pin Hub and Set Screw / 12.70	AGMA 10 / Bronze with 302 Stainless Hub and Springs	6.08
					<i>0.250</i>	<i>0.427</i>	<i>0.187</i>			<i>0.239</i>
# WG1R48-1-070-05HS0476-BRZ	Gear with Hub	70 / 37.04	Right Hand	Single / Type G1	4.757	10.351	4.762	9.52 / Set Screw	AGMA Q10 / Bronze	5.59
					<i>0.187</i>	<i>0.408</i>	<i>0.187</i>			<i>0.220</i>

Indicates item not stocked at time of printing - Please enquire for lead time

E&OE Pricing and all details subject to change without notice - Copyright Miniature Bearings Australia Pty Ltd

MBA Size Listings are a guide to sizes only and must not be solely relied on for critical design information.

Worms and Worm Gears - 48 Pitch (Series 1) - Metallic

Part Number	Gear or Worm	Teeth / PCD (No. / mm)	Direction	Starts / Type	Bore (B) mm	Overall Width or Length (w) mm	Face Width (fw) mm	Hub Diameter (D) / Lock Method mm	Quality / Material	Hub Projection (p) mm
					<i>inches</i>	<i>inches</i>	<i>inches</i>	<i>inches</i>		<i>inches</i>
# WG1R48-1A-072-05HC0635-BRZ	Gear with Hub - Antibacklash	72 / 38.10	Right Hand / Antibacklash	Single / Type Not Shown	6.345	10.846	4.762	Clamp Hub / 7.92	AGMA 10 / Bronze with 302 Stainless Hub and Springs	6.08
					<i>0.250</i>	<i>0.427</i>	<i>0.187</i>			<i>0.239</i>
# WG1R48-1A-072-05HS0635-BRZ	Gear with Hub - Antibacklash	72 / 38.10	Right Hand / Antibacklash	Single / Type G3	6.345	10.846	4.762	Pin Hub and Set Screw / 12.70	AGMA 10 / Bronze with 302 Stainless Hub and Springs	6.08
					<i>0.250</i>	<i>0.427</i>	<i>0.187</i>			<i>0.239</i>
# WG1R48-1A-072-05HC0317-BRZ	Gear with Hub - Antibacklash	72 / 38.10	Right Hand / Antibacklash	Single / Type Not Shown	3.169	10.846	4.762	Clamp Hub / 4.76	AGMA 10 / Bronze with 302 Stainless Hub and Springs	6.08
					<i>0.125</i>	<i>0.427</i>	<i>0.187</i>			<i>0.239</i>
# WG1R48-1A-072-05HC0476-BRZ	Gear with Hub - Antibacklash	72 / 38.10	Right Hand / Antibacklash	Single / Type Not Shown	4.757	10.846	4.762	Clamp Hub / 6.35	AGMA 10 / Bronze with 302 Stainless Hub and Springs	6.08
					<i>0.187</i>	<i>0.427</i>	<i>0.187</i>			<i>0.239</i>
# WG1R48-1A-072-05HS0476-BRZ	Gear with Hub - Antibacklash	72 / 38.10	Right Hand / Antibacklash	Single / Type G3	4.757	10.846	4.762	Pin Hub and Set Screw / 9.52	AGMA 10 / Bronze with 302 Stainless Hub and Springs	6.08
					<i>0.187</i>	<i>0.427</i>	<i>0.187</i>			<i>0.239</i>

Indicates item not stocked at time of printing - Please enquire for lead time

E&OE Pricing and all details subject to change without notice - Copyright Miniature Bearings Australia Pty Ltd

MBA Size Listings are a guide to sizes only and must not be solely relied on for critical design information.

Worms and Worm Gears - 48 Pitch (Series 1) - Metallic

Part Number	Gear or Worm	Teeth / PCD (No. / mm)	Direction	Starts / Type	Bore (B) mm	Overall Width or Length (w) mm	Face Width (fw) mm	Hub Diameter (D) / Lock Method mm	Quality / Material	Hub Projection (p) mm
					<i>inches</i>	<i>inches</i>	<i>inches</i>	<i>inches</i>		<i>inches</i>
# WG1R48-1A-072-05HS0317-BRZ	Gear with Hub - Antibacklash	72 / 38.10	Right Hand / Antibacklash	Single / Type G3	3.169	10.846	4.762	Pin Hub and Set Screw / 7.92	AGMA 10 / Bronze with 302 Stainless Hub and Springs	6.08
					<i>0.125</i>	<i>0.427</i>	<i>0.187</i>			<i>0.239</i>
# WG1R48-1-075-05HS0476-BRZ	Gear with Hub	75 / 39.69	Right Hand	Single / Type G1	4.757	10.351	4.762	9.52 / Set Screw	AGMA Q10 / Bronze	5.59
					<i>0.187</i>	<i>0.408</i>	<i>0.187</i>			<i>0.220</i>
# WG1R48-1-075-05HS0317-BRZ	Gear with Hub	75 / 39.69	Right Hand	Single / Type G1	3.170	10.351	4.762	7.92 / Set Screw	AGMA Q10 / Bronze	5.59
					<i>0.125</i>	<i>0.408</i>	<i>0.187</i>			<i>0.220</i>
# WG1R48-1-075-05HS0635-BRZ	Gear with Hub	75 / 39.69	Right Hand	Single / Type G1	6.345	10.351	4.762	12.70 / Set Screw	AGMA Q10 / Bronze	5.59
					<i>0.250</i>	<i>0.408</i>	<i>0.187</i>			<i>0.220</i>
# WG1R48-1A-080-05HS0635-BRZ	Gear with Hub - Antibacklash	80 / 42.33	Right Hand / Antibacklash	Single / Type G3	6.345	10.846	4.762	Pin Hub and Set Screw / 12.70	AGMA 10 / Bronze with 302 Stainless Hub and Springs	6.08
					<i>0.250</i>	<i>0.427</i>	<i>0.187</i>			<i>0.239</i>
# WG1R48-1A-080-05HS0476-BRZ	Gear with Hub - Antibacklash	80 / 42.33	Right Hand / Antibacklash	Single / Type G3	4.757	10.846	4.762	Pin Hub and Set Screw / 9.52	AGMA 10 / Bronze with 302 Stainless Hub and Springs	6.08
					<i>0.187</i>	<i>0.427</i>	<i>0.187</i>			<i>0.239</i>

Indicates item not stocked at time of printing - Please enquire for lead time

E&OE Pricing and all details subject to change without notice - Copyright Miniature Bearings Australia Pty Ltd

MBA Size Listings are a guide to sizes only and must not be solely relied on for critical design information.

Worms and Worm Gears - 48 Pitch (Series 1) - Metallic

Part Number	Gear or Worm	Teeth / PCD (No. / mm)	Direction	Starts / Type	Bore (B) mm	Overall Width or Length (w) mm	Face Width (fw) mm	Hub Diameter (D) / Lock Method mm	Quality / Material	Hub Projection (p) mm
					<i>inches</i>	<i>inches</i>	<i>inches</i>	<i>inches</i>		<i>inches</i>
# WG1R48-1A-080-05HC0317-BRZ	Gear with Hub - Antibacklash	80 / 42.33	Right Hand / Antibacklash	Single / Type Not Shown	3.169	10.846	4.762	Clamp Hub / 4.76	AGMA 10 / Bronze with 302 Stainless Hub and Springs	6.08
					<i>0.125</i>	<i>0.427</i>	<i>0.187</i>			<i>0.239</i>
# WG1R48-1A-080-05HC0635-BRZ	Gear with Hub - Antibacklash	80 / 42.33	Right Hand / Antibacklash	Single / Type Not Shown	6.345	10.846	4.762	Clamp Hub / 7.92	AGMA 10 / Bronze with 302 Stainless Hub and Springs	6.08
					<i>0.250</i>	<i>0.427</i>	<i>0.187</i>			<i>0.239</i>
# WG1R48-1-080-05HS0635-BRZ	Gear with Hub	80 / 42.33	Right Hand	Single / Type G1	6.345	10.351	4.762	12.70 / Set Screw	AGMA Q10 / Bronze	5.59
					<i>0.250</i>	<i>0.408</i>	<i>0.187</i>			<i>0.220</i>
# WG1R48-1A-080-05HS0317-BRZ	Gear with Hub - Antibacklash	80 / 42.33	Right Hand / Antibacklash	Single / Type G3	3.169	10.846	4.762	Pin Hub and Set Screw / 7.92	AGMA 10 / Bronze with 302 Stainless Hub and Springs	6.08
					<i>0.125</i>	<i>0.427</i>	<i>0.187</i>			<i>0.239</i>
# WG1R48-1-080-05HS0317-BRZ	Gear with Hub	80 / 42.33	Right Hand	Single / Type G1	3.170	10.351	4.762	7.92 / Set Screw	AGMA Q10 / Bronze	5.59
					<i>0.125</i>	<i>0.408</i>	<i>0.187</i>			<i>0.220</i>
# WG1R48-1A-080-05HC0476-BRZ	Gear with Hub - Antibacklash	80 / 42.33	Right Hand / Antibacklash	Single / Type Not Shown	4.757	10.846	4.762	Clamp Hub / 6.35	AGMA 10 / Bronze with 302 Stainless Hub and Springs	6.08
					<i>0.187</i>	<i>0.427</i>	<i>0.187</i>			<i>0.239</i>

Indicates item not stocked at time of printing - Please enquire for lead time

E&OE Pricing and all details subject to change without notice - Copyright Miniature Bearings Australia Pty Ltd

MBA Size Listings are a guide to sizes only and must not be solely relied on for critical design information.

Worms and Worm Gears - 48 Pitch (Series 1) - Metallic

Part Number	Gear or Worm	Teeth / PCD (No. / mm)	Direction	Starts / Type	Bore (B) mm	Overall Width or Length (w) mm	Face Width (fw) mm	Hub Diameter (D) / Lock Method mm	Quality / Material	Hub Projection (p) mm
					<i>inches</i>	<i>inches</i>	<i>inches</i>	<i>inches</i>		<i>inches</i>
# WG1R48-1-080-05HS0476-BRZ	Gear with Hub	80 / 42.33	Right Hand	Single / Type G1	4.757	10.351	4.762	9.52 / Set Screw	AGMA Q10 / Bronze	5.59
					<i>0.187</i>	<i>0.408</i>	<i>0.187</i>			<i>0.220</i>
# WG1R48-1-085-05HS0317-BRZ	Gear with Hub	85 / 44.98	Right Hand	Single / Type G1	3.170	10.351	4.762	7.92 / Set Screw	AGMA Q10 / Bronze	5.59
					<i>0.125</i>	<i>0.408</i>	<i>0.187</i>			<i>0.220</i>
# WG1R48-1-085-05HS0476-BRZ	Gear with Hub	85 / 44.98	Right Hand	Single / Type G1	4.757	10.351	4.762	9.52 / Set Screw	AGMA Q10 / Bronze	5.59
					<i>0.187</i>	<i>0.408</i>	<i>0.187</i>			<i>0.220</i>
# WG1R48-1-085-05HS0635-BRZ	Gear with Hub	85 / 44.98	Right Hand	Single / Type G1	6.345	10.351	4.762	12.70 / Set Screw	AGMA Q10 / Bronze	5.59
					<i>0.250</i>	<i>0.408</i>	<i>0.187</i>			<i>0.220</i>
# WG1R48-1-090-05HS0317-BRZ	Gear with Hub	90 / 47.63	Right Hand	Single / Type G1	3.170	10.351	4.762	7.92 / Set Screw	AGMA Q10 / Bronze	5.59
					<i>0.125</i>	<i>0.408</i>	<i>0.187</i>			<i>0.220</i>
# WG1R48-1A-090-05HS0317-BRZ	Gear with Hub - Antibacklash	90 / 47.63	Right Hand / Antibacklash	Single / Type G3	3.169	10.846	4.762	Pin Hub and Set Screw / 7.92	AGMA 10 / Bronze with 302 Stainless Hub and Springs	6.08
					<i>0.125</i>	<i>0.427</i>	<i>0.187</i>			<i>0.239</i>
# WG1R48-1-090-05HS0476-BRZ	Gear with Hub	90 / 47.63	Right Hand	Single / Type G1	4.757	10.351	4.762	9.52 / Set Screw	AGMA Q10 / Bronze	5.59
					<i>0.187</i>	<i>0.408</i>	<i>0.187</i>			<i>0.220</i>

Indicates item not stocked at time of printing - Please enquire for lead time

E&OE Pricing and all details subject to change without notice - Copyright Miniature Bearings Australia Pty Ltd

MBA Size Listings are a guide to sizes only and must not be solely relied on for critical design information.

Worms and Worm Gears - 48 Pitch (Series 1) - Metallic

Part Number	Gear or Worm	Teeth / PCD (No. / mm)	Direction	Starts / Type	Bore (B) mm	Overall Width or Length (w) mm	Face Width (fw) mm	Hub Diameter (D) / Lock Method mm	Quality / Material	Hub Projection (p) mm
					<i>inches</i>	<i>inches</i>	<i>inches</i>	<i>inches</i>		<i>inches</i>
# WG1R48-1A-090-05HC0317-BRZ	Gear with Hub - Antibacklash	90 / 47.63	Right Hand / Antibacklash	Single / Type Not Shown	3.169	10.846	4.762	Clamp Hub / 4.76	AGMA 10 / Bronze with 302 Stainless Hub and Springs	6.08
					<i>0.125</i>	<i>0.427</i>	<i>0.187</i>			<i>0.239</i>
# WG1R48-1A-090-05HS0635-BRZ	Gear with Hub - Antibacklash	90 / 47.63	Right Hand / Antibacklash	Single / Type G3	6.345	10.846	4.762	Pin Hub and Set Screw / 12.70	AGMA 10 / Bronze with 302 Stainless Hub and Springs	6.08
					<i>0.250</i>	<i>0.427</i>	<i>0.187</i>			<i>0.239</i>
# WG1R48-1A-090-05HC0476-BRZ	Gear with Hub - Antibacklash	90 / 47.63	Right Hand / Antibacklash	Single / Type Not Shown	4.757	10.846	4.762	Clamp Hub / 6.35	AGMA 10 / Bronze with 302 Stainless Hub and Springs	6.08
					<i>0.187</i>	<i>0.427</i>	<i>0.187</i>			<i>0.239</i>
# WG1R48-1A-090-05HC0635-BRZ	Gear with Hub - Antibacklash	90 / 47.63	Right Hand / Antibacklash	Single / Type Not Shown	6.345	10.846	4.762	Clamp Hub / 7.92	AGMA 10 / Bronze with 302 Stainless Hub and Springs	6.08
					<i>0.250</i>	<i>0.427</i>	<i>0.187</i>			<i>0.239</i>
# WG1R48-1-090-05HS0635-BRZ	Gear with Hub	90 / 47.63	Right Hand	Single / Type G1	6.345	10.351	4.762	12.70 / Set Screw	AGMA Q10 / Bronze	5.59
					<i>0.250</i>	<i>0.408</i>	<i>0.187</i>			<i>0.220</i>

Indicates item not stocked at time of printing - Please enquire for lead time

E&OE Pricing and all details subject to change without notice - Copyright Miniature Bearings Australia Pty Ltd

MBA Size Listings are a guide to sizes only and must not be solely relied on for critical design information.

Worms and Worm Gears - 48 Pitch (Series 1) - Metallic

Part Number	Gear or Worm	Teeth / PCD (No. / mm)	Direction	Starts / Type	Bore (B) mm	Overall Width or Length (w) mm	Face Width (fw) mm	Hub Diameter (D) / Lock Method mm	Quality / Material	Hub Projection (p) mm
					<i>inches</i>	<i>inches</i>	<i>inches</i>	<i>inches</i>		<i>inches</i>
# WG1R48-1A-090-05HS0476-BRZ	Gear with Hub - Antibacklash	90 / 47.63	Right Hand / Antibacklash	Single / Type G3	4.757	10.846	4.762	Pin Hub and Set Screw / 9.52	AGMA 10 / Bronze with 302 Stainless Hub and Springs	6.08
					<i>0.187</i>	<i>0.427</i>	<i>0.187</i>			<i>0.239</i>
# WG1R48-1-095-05HS0317-BRZ	Gear with Hub	95 / 50.27	Right Hand	Single / Type G1	3.170	10.351	4.762	7.92 / Set Screw	AGMA Q10 / Bronze	5.59
					<i>0.125</i>	<i>0.408</i>	<i>0.187</i>			<i>0.220</i>
# WG1R48-1-095-05HS0635-BRZ	Gear with Hub	95 / 50.27	Right Hand	Single / Type G1	6.345	10.351	4.762	12.70 / Set Screw	AGMA Q10 / Bronze	5.59
					<i>0.250</i>	<i>0.408</i>	<i>0.187</i>			<i>0.220</i>
# WG1R48-1-095-05HS0476-BRZ	Gear with Hub	95 / 50.27	Right Hand	Single / Type G1	4.757	10.351	4.762	9.52 / Set Screw	AGMA Q10 / Bronze	5.59
					<i>0.187</i>	<i>0.408</i>	<i>0.187</i>			<i>0.220</i>
# WG1R48-1A-096-05HC0635-BRZ	Gear with Hub - Antibacklash	96 / 50.80	Right Hand / Antibacklash	Single / Type Not Shown	6.345	10.846	4.762	Clamp Hub / 7.92	AGMA 10 / Bronze with 302 Stainless Hub and Springs	6.08
					<i>0.250</i>	<i>0.427</i>	<i>0.187</i>			<i>0.239</i>
# WG1R48-1A-096-05HS0635-BRZ	Gear with Hub - Antibacklash	96 / 50.80	Right Hand / Antibacklash	Single / Type G3	6.345	10.846	4.762	Pin Hub and Set Screw / 12.70	AGMA 10 / Bronze with 302 Stainless Hub and Springs	6.08
					<i>0.250</i>	<i>0.427</i>	<i>0.187</i>			<i>0.239</i>

Indicates item not stocked at time of printing - Please enquire for lead time

E&OE Pricing and all details subject to change without notice - Copyright Miniature Bearings Australia Pty Ltd

MBA Size Listings are a guide to sizes only and must not be solely relied on for critical design information.

Worms and Worm Gears - 48 Pitch (Series 1) - Metallic

Part Number	Gear or Worm	Teeth / PCD (No. / mm)	Direction	Starts / Type	Bore (B) mm	Overall Width or Length (w) mm	Face Width (fw) mm	Hub Diameter (D) / Lock Method mm	Quality / Material	Hub Projection (p) mm
					<i>inches</i>	<i>inches</i>	<i>inches</i>	<i>inches</i>		<i>inches</i>
# WG1R48-1A-096-05HC0476-BRZ	Gear with Hub - Antibacklash	96 / 50.80	Right Hand / Antibacklash	Single / Type Not Shown	4.757	10.846	4.762	Clamp Hub / 6.35	AGMA 10 / Bronze with 302 Stainless Hub and Springs	6.08
					<i>0.187</i>	<i>0.427</i>	<i>0.187</i>			<i>0.239</i>
# WG1R48-1A-096-05HS0476-BRZ	Gear with Hub - Antibacklash	96 / 50.80	Right Hand / Antibacklash	Single / Type G3	4.757	10.846	4.762	Pin Hub and Set Screw / 9.52	AGMA 10 / Bronze with 302 Stainless Hub and Springs	6.08
					<i>0.187</i>	<i>0.427</i>	<i>0.187</i>			<i>0.239</i>
# WG1R48-1A-096-05HS0317-BRZ	Gear with Hub - Antibacklash	96 / 50.80	Right Hand / Antibacklash	Single / Type G3	3.169	10.846	4.762	Pin Hub and Set Screw / 7.92	AGMA 10 / Bronze with 302 Stainless Hub and Springs	6.08
					<i>0.125</i>	<i>0.427</i>	<i>0.187</i>			<i>0.239</i>
# WG1R48-1A-096-05HC0317-BRZ	Gear with Hub - Antibacklash	96 / 50.80	Right Hand / Antibacklash	Single / Type Not Shown	3.169	10.846	4.762	Clamp Hub / 4.76	AGMA 10 / Bronze with 302 Stainless Hub and Springs	6.08
					<i>0.125</i>	<i>0.427</i>	<i>0.187</i>			<i>0.239</i>
# WG1R48-1A-100-05HS0317-BRZ	Gear with Hub - Antibacklash	100 / 52.92	Right Hand / Antibacklash	Single / Type G3	3.169	10.846	4.762	Pin Hub and Set Screw / 7.92	AGMA 10 / Bronze with 302 Stainless Hub and Springs	6.08
					<i>0.125</i>	<i>0.427</i>	<i>0.187</i>			<i>0.239</i>

Indicates item not stocked at time of printing - Please enquire for lead time

E&OE Pricing and all details subject to change without notice - Copyright Miniature Bearings Australia Pty Ltd

MBA Size Listings are a guide to sizes only and must not be solely relied on for critical design information.

Worms and Worm Gears - 48 Pitch (Series 1) - Metallic

Part Number	Gear or Worm	Teeth / PCD (No. / mm)	Direction	Starts / Type	Bore (B) mm	Overall Width or Length (w) mm	Face Width (fw) mm	Hub Diameter (D) / Lock Method mm	Quality / Material	Hub Projection (p) mm
					<i>inches</i>	<i>inches</i>	<i>inches</i>	<i>inches</i>		<i>inches</i>
# WG1R48-1A-100-05HC0635-BRZ	Gear with Hub - Antibacklash	100 / 52.92	Right Hand / Antibacklash	Single / Type Not Shown	6.345	10.846	4.762	Clamp Hub / 7.92	AGMA 10 / Bronze with 302 Stainless Hub and Springs	6.08
					<i>0.250</i>	<i>0.427</i>	<i>0.187</i>			<i>0.239</i>
# WG1R48-1A-100-05HC0476-BRZ	Gear with Hub - Antibacklash	100 / 52.92	Right Hand / Antibacklash	Single / Type Not Shown	4.757	10.846	4.762	Clamp Hub / 6.35	AGMA 10 / Bronze with 302 Stainless Hub and Springs	6.08
					<i>0.187</i>	<i>0.427</i>	<i>0.187</i>			<i>0.239</i>
# WG1R48-1A-100-05HS0476-BRZ	Gear with Hub - Antibacklash	100 / 52.92	Right Hand / Antibacklash	Single / Type G3	4.757	10.846	4.762	Pin Hub and Set Screw / 9.52	AGMA 10 / Bronze with 302 Stainless Hub and Springs	6.08
					<i>0.187</i>	<i>0.427</i>	<i>0.187</i>			<i>0.239</i>
# WG1R48-1A-100-05HS0635-BRZ	Gear with Hub - Antibacklash	100 / 52.92	Right Hand / Antibacklash	Single / Type G3	6.345	10.846	4.762	Pin Hub and Set Screw / 12.70	AGMA 10 / Bronze with 302 Stainless Hub and Springs	6.08
					<i>0.250</i>	<i>0.427</i>	<i>0.187</i>			<i>0.239</i>
# WG1R48-1-100-05HS0635-BRZ	Gear with Hub	100 / 52.92	Right Hand	Single / Type G1	6.345	10.351	4.762	12.70 / Set Screw	AGMA Q10 / Bronze	5.59
					<i>0.250</i>	<i>0.408</i>	<i>0.187</i>			<i>0.220</i>
# WG1R48-1-100-05HS0476-BRZ	Gear with Hub	100 / 52.92	Right Hand	Single / Type G1	4.757	10.351	4.762	9.52 / Set Screw	AGMA Q10 / Bronze	5.59
					<i>0.187</i>	<i>0.408</i>	<i>0.187</i>			<i>0.220</i>

Indicates item not stocked at time of printing - Please enquire for lead time

E&OE Pricing and all details subject to change without notice - Copyright Miniature Bearings Australia Pty Ltd

MBA Size Listings are a guide to sizes only and must not be solely relied on for critical design information.

Worms and Worm Gears - 48 Pitch (Series 1) - Metallic

Part Number	Gear or Worm	Teeth / PCD (No. / mm)	Direction	Starts / Type	Bore (B) mm	Overall Width or Length (w) mm	Face Width (fw) mm	Hub Diameter (D) / Lock Method mm	Quality / Material	Hub Projection (p) mm
					<i>inches</i>	<i>inches</i>	<i>inches</i>	<i>inches</i>		<i>inches</i>
# WG1R48-1A-100-05HC0317-BRZ	Gear with Hub - Antibacklash	100 / 52.92	Right Hand / Antibacklash	Single / Type Not Shown	3.169	10.846	4.762	Clamp Hub / 4.76	AGMA 10 / Bronze with 302 Stainless Hub and Springs	6.08
					<i>0.125</i>	<i>0.427</i>	<i>0.187</i>			<i>0.239</i>
# WG1R48-1-100-05HS0317-BRZ	Gear with Hub	100 / 52.92	Right Hand	Single / Type G1	3.170	10.351	4.762	7.92 / Set Screw	AGMA Q10 / Bronze	5.59
					<i>0.125</i>	<i>0.408</i>	<i>0.187</i>			<i>0.220</i>
# WG1R48-1-105-05HS0476-BRZ	Gear with Hub	105 / 55.56	Right Hand	Single / Type G1	4.757	10.351	4.762	9.52 / Set Screw	AGMA Q10 / Bronze	5.59
					<i>0.187</i>	<i>0.408</i>	<i>0.187</i>			<i>0.220</i>
# WG1R48-1-105-05HS0635-BRZ	Gear with Hub	105 / 55.56	Right Hand	Single / Type G1	6.345	10.351	4.762	12.70 / Set Screw	AGMA Q10 / Bronze	5.59
					<i>0.250</i>	<i>0.408</i>	<i>0.187</i>			<i>0.220</i>
# WG1R48-1-105-05HS0317-BRZ	Gear with Hub	105 / 55.56	Right Hand	Single / Type G1	3.170	10.351	4.762	7.92 / Set Screw	AGMA Q10 / Bronze	5.59
					<i>0.125</i>	<i>0.408</i>	<i>0.187</i>			<i>0.220</i>
# WG1R48-1-110-05HS0635-BRZ	Gear with Hub	110 / 58.21	Right Hand	Single / Type G1	6.345	10.351	4.762	12.70 / Set Screw	AGMA Q10 / Bronze	5.59
					<i>0.250</i>	<i>0.408</i>	<i>0.187</i>			<i>0.220</i>
# WG1R48-1-110-05HS0476-BRZ	Gear with Hub	110 / 58.21	Right Hand	Single / Type G1	4.757	10.351	4.762	9.52 / Set Screw	AGMA Q10 / Bronze	5.59
					<i>0.187</i>	<i>0.408</i>	<i>0.187</i>			<i>0.220</i>
# WG1R48-1-110-05HS0317-BRZ	Gear with Hub	110 / 58.21	Right Hand	Single / Type G1	3.170	10.351	4.762	7.92 / Set Screw	AGMA Q10 / Bronze	5.59
					<i>0.125</i>	<i>0.408</i>	<i>0.187</i>			<i>0.220</i>

Indicates item not stocked at time of printing - Please enquire for lead time

E&OE Pricing and all details subject to change without notice - Copyright Miniature Bearings Australia Pty Ltd

MBA Size Listings are a guide to sizes only and must not be solely relied on for critical design information.

Worms and Worm Gears - 48 Pitch (Series 1) - Metallic

Part Number	Gear or Worm	Teeth / PCD (No. / mm)	Direction	Starts / Type	Bore (B) mm	Overall Width or Length (w) mm	Face Width (fw) mm	Hub Diameter (D) / Lock Method mm	Quality / Material	Hub Projection (p) mm
					<i>inches</i>	<i>inches</i>	<i>inches</i>	<i>inches</i>		<i>inches</i>
# WG1R48-1-115-05HS0476-BRZ	Gear with Hub	115 / 60.86	Right Hand	Single / Type G1	4.757	10.351	4.762	9.52 / Set Screw	AGMA Q10 / Bronze	5.59
					<i>0.187</i>	<i>0.408</i>	<i>0.187</i>			<i>0.220</i>
# WG1R48-1-115-05HS0635-BRZ	Gear with Hub	115 / 60.86	Right Hand	Single / Type G1	6.345	10.351	4.762	12.70 / Set Screw	AGMA Q10 / Bronze	5.59
					<i>0.250</i>	<i>0.408</i>	<i>0.187</i>			<i>0.220</i>
# WG1R48-1-115-05HS0317-BRZ	Gear with Hub	115 / 60.86	Right Hand	Single / Type G1	3.170	10.351	4.762	7.92 / Set Screw	AGMA Q10 / Bronze	5.59
					<i>0.125</i>	<i>0.408</i>	<i>0.187</i>			<i>0.220</i>
# WG1R48-1-120-05HS0317-BRZ	Gear with Hub	120 / 63.50	Right Hand	Single / Type G1	3.170	10.351	4.762	7.92 / Set Screw	AGMA Q10 / Bronze	5.59
					<i>0.125</i>	<i>0.408</i>	<i>0.187</i>			<i>0.220</i>
# WG1R48-1-120-05HS0635-BRZ	Gear with Hub	120 / 63.50	Right Hand	Single / Type G1	6.345	10.351	4.762	12.70 / Set Screw	AGMA Q10 / Bronze	5.59
					<i>0.250</i>	<i>0.408</i>	<i>0.187</i>			<i>0.220</i>
# WG1R48-1-120-05HS0476-BRZ	Gear with Hub	120 / 63.50	Right Hand	Single / Type G1	4.757	10.351	4.762	9.52 / Set Screw	AGMA Q10 / Bronze	5.59
					<i>0.187</i>	<i>0.408</i>	<i>0.187</i>			<i>0.220</i>
# WG1R48-1-180-05HS0635-BRZ	Gear with Hub	180 / 95.25	Right Hand	Single / Type G1	6.345	10.351	4.762	12.70 / Set Screw	AGMA Q10 / Bronze	5.59
					<i>0.250</i>	<i>0.408</i>	<i>0.187</i>			<i>0.220</i>
# WG1R48-1-360-05HS0635-BRZ	Gear with Hub (2 Piece Construction)	360 / 190.50	Right Hand	Single / Special Type	6.345	10.351	4.762	12.700 Set Screw	AGMA Q10 / Bronze	7.112
					<i>0.250</i>	<i>0.408</i>	<i>0.187</i>			<i>0.280</i>

Indicates item not stocked at time of printing - Please enquire for lead time

E&OE Pricing and all details subject to change without notice - Copyright Miniature Bearings Australia Pty Ltd

MBA Size Listings are a guide to sizes only and must not be solely relied on for critical design information.

Worms and Worm Gears - 48 Pitch (Series 1) - Metallic

Part Number	Gear or Worm	Teeth / PCD (No. / mm)	Direction	Starts / Type	Bore (B) mm	Overall Width or Length (w) mm	Face Width (fw) mm	Hub Diameter (D) / Lock Method mm	Quality / Material	Hub Projection (p) mm
					<i>inches</i>	<i>inches</i>	<i>inches</i>	<i>inches</i>		<i>inches</i>
WM1R48-1-019HS03.17-303	Worm with Single Hub	- / 8.382	Right Hand	Single / Type W1	3.170	19.050	14.288	7.925 / Set Screw	AGMA 10 / 303 Stainless Not Hardened	4.762
					<i>0.125</i>	<i>0.750</i>	<i>0.563</i>			<i>0.187</i>
WM1R48-1-019HS04.76-303	Worm with Single Hub	- / 8.382	Right Hand	Single / Type W1	4.757	19.050	14.288	7.925 / Set Screw	AGMA 10 / 303 Stainless Not Hardened	4.762
					<i>0.187</i>	<i>0.750</i>	<i>0.563</i>			<i>0.187</i>

Indicates item not stocked at time of printing - Please enquire for lead time

E&OE Pricing and all details subject to change without notice - Copyright Miniature Bearings Australia Pty Ltd

MBA Size Listings are a guide to sizes only and must not be solely relied on for critical design information.



DISTRIBUTED BY

Ask us to put your name and address here

<http://www.minibearings.com.au/product>

Ph +61 7 3245 7977

Fax +61 7 3245 1017

Catalogue requests to catalogues@minibearings.com.au

